

Ombrea®

Freistehende Bioklimatische Pergola 3x4M ELMO

Anthrazit

Aufbauanleitung

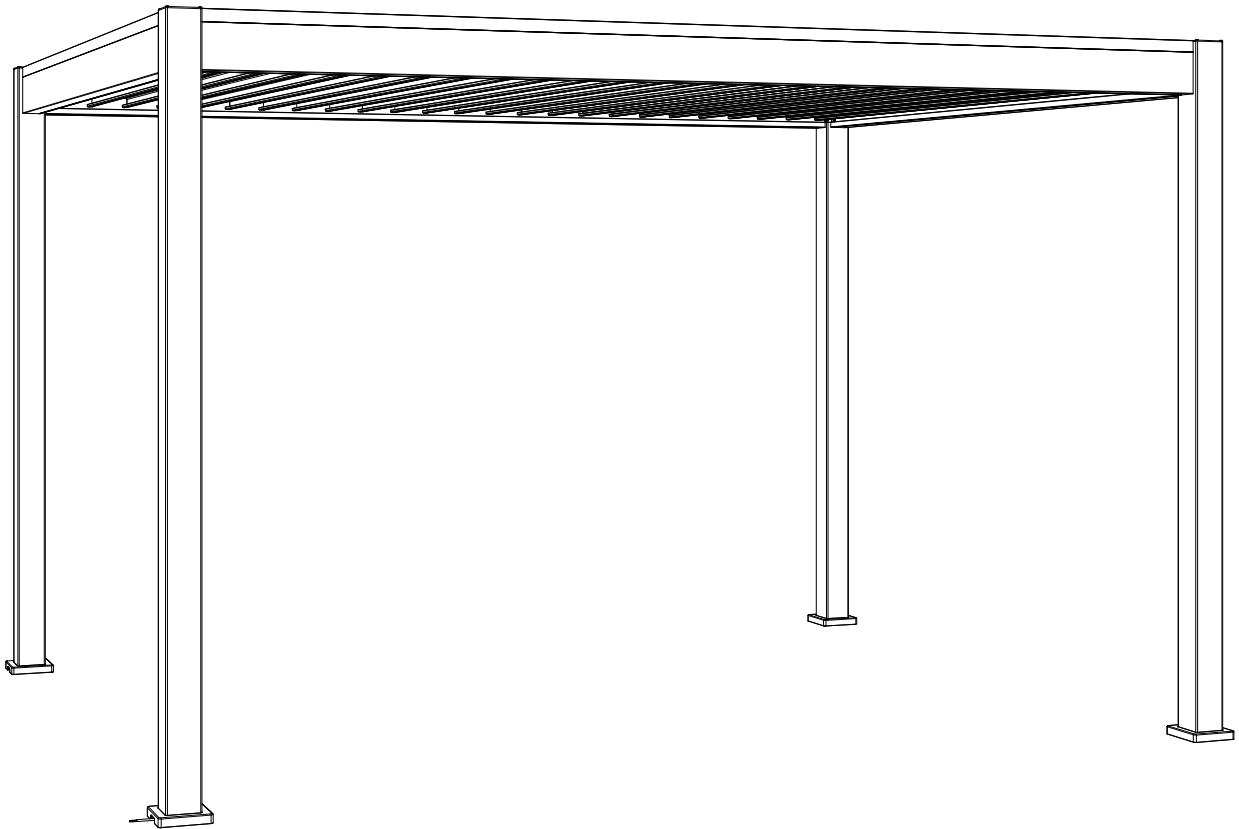

Bioklimatische freistehende Pergola 3 x 4 m

Bewahren Sie diese Anleitung während der gesamten Lebensdauer des Produkts auf.

Bitte lesen Sie die Anleitung vor dem Zusammenbau aufmerksam durch. Der Nutzer haftet für Schäden oder Verletzungen, die durch unsachgemäße Verwendung verursacht werden.

1. VORSICHTSMAßNAHMEN BEI DER VERWENDUNG

Dieses Produkt darf nicht bei starken Unwettern verwendet werden:

Wie Gewitter, starker Wind, Hagel oder Schnee. Wir garantieren die Widerstandsfähigkeit der Pergola bei Windgeschwindigkeiten von bis zu 100 km/h und einem maximalen Schneegewicht von 50 kg/m².

Bei starkem Wind oder Schnee wird dringend empfohlen, die Lamellen in geöffneter Position zu lassen. Bitte nicht vergessen, den Schnee vom Dach zu entfernen, um eine starke Überlastung der Lamellen zu vermeiden.

Unsere Pergola kann starke Regenfällen standhalten, aber wir können keine absolute Wasserdichtigkeit garantieren. Bei außergewöhnlichen Wetterereignissen kann die Wasserdichtigkeit beeinträchtigt werden. Lassen Sie keine feuchtigkeitsempfindlichen Produkte unter der Pergola liegen.

Steigen Sie nicht auf das Dach oder die Struktur der Pergola.

2. AUFBAUTIPPS

Je nach Standort und Fläche kann es sein, dass für den Bau eine Baugenehmigung oder ein Antrag auf Baugenehmigung erforderlich ist. Wir empfehlen Ihnen, sich vor dem Aufbau an Ihre Stadtverwaltung zu wenden, um die entsprechenden Informationen zu erhalten.

Produktmontage :

- Entfernen Sie vor der Installation die Schutzfolien von allen Teilen.
- Geschätzte Dauer: 1 Stunde
- 2 bis 3 Personen werden benötigt
- Lassen Sie Kinder nicht in der Nähe des Montagebereichs spielen
- Achten Sie auf Klemmgefahr
- Ziehen Sie die Schrauben nie vollständig an, bevor Sie den entsprechenden Teil zusammengebaut haben
- Alle Schritte des Zusammenbaus müssen genau befolgt werden
- Niveau, Diagonalen und Auslotung kontrollieren
- Befestigen Sie die Pergola erst nach dem Zusammenbau

Es dürfen keine Veränderungen am Produkt vorgenommen werden. Vom Benutzer veränderte Produkte fallen nicht mehr unter die Garantie des Herstellers.

Der Standort sollte mit Bedacht gewählt werden. Es wird empfohlen, die Pergola nicht bei Regen, in der Hauptwindrichtung oder unter einem Baum aufzustellen.

Die Pergola muss auf einem ausreichend stabilen und ebenen Fundament errichtet werden. Es wird empfohlen, sie auf einer Betonplatte oder auf 25x25 cm großen Betonklötzen an jedem Pfosten zu errichten. Wir bitten Sie, die Pergola mit Hilfe der TO-Teile korrekt im Boden zu verankern.

Wenn Sie Ihre Pergola in der Nähe Ihres Hauses oder eines Gebäudes aufstellen möchten, achten Sie darauf, dass Regenrinnen vorhanden sind, damit das Wasser abfließen kann. Die Pergola kann es nicht aushalten und auch keine perfekte Abdichtung garantieren, wenn Regenwasser von Ihrem Haus in die Pergola fließt.

Bei Nichteinhaltung der Montageempfehlungen kann die Garantie nicht in Anspruch genommen werden.

3. PFLEGE DER PERGOLA

Eine regelmäßige Pflege ist notwendig, um die Langlebigkeit und das Design zu gewährleisten. Wir empfehlen :

- Waschen Sie Ihre Pergola ein- bis zweimal im Jahr mit Süßwasser und einem Schwamm oder Tuch. Verwenden Sie keine aggressiven Reinigungsmittel oder Scheuermittel.
- Überprüfen Sie regelmäßig (mindestens einmal pro Jahr), ob die Schrauben fest angezogen sind.
- Ölen Sie die Eisenwaren regelmäßig (mindestens einmal pro Jahr).
- Achten Sie darauf, dass nichts den Wasserabfluss in den Regenrinnen behindert (Blätter, Äste...).
- Entfernen Sie Wasser, das sich um die Füße der Pergola herum ansammelt (heben Sie die Abdeckungen an).

4. GARANTIE

Wir garantieren die Verfügbarkeit von Ersatzteilen für 2 oder 5 Jahre (je nach Produkt). Die Garantie gilt nur, wenn die Hinweise zu Lagerung, Montage, Gebrauch und Wartung beachtet werden.

Die Garantie umfasst nicht :

- Normale Gebrauchsspuren der Produkte.
- Verlust oder Bruch von Teilen beim Auspacken oder bei der Montage.
- Mangel an vernünftiger Sorgfalt, Vernachlässigung, Vandalismus, Einwirkung fremder Gegenstände, Gewaltanwendung, Kontakt mit Schleifmitteln, Ästhetik, Ausbau, Wiederaufbau oder Verlegung des Standorts.
- Höhere Gewalt: Hagel, starke Winde, Stürme, Schnee, Überschwemmungen, Blitzschlag...

Die Garantie umfasst nur den Ersatz des Ersatzteils oder des gelieferten Produkts, unter Ausschluss jeglicher Kosten und Entschädigungen jeglicher Art.

Die Garantie muss bei der Verkaufsstelle (Geschäft oder Internetseite) beantragt werden, bei der Sie Ihr Produkt gekauft haben.









5. TEILELISTE (PRO KARTON)









Bevor Sie mit der Montage Ihrer Bioklimatischen Pergola beginnen, müssen Sie überprüfen, ob alle Teile vorhanden und unbeschädigt sind. Fehlende Teile müssen innerhalb von 10 Tagen nach dem Kauf gemeldet werden. Sie können sich an Ihren Händler wenden oder die Anfrage direkt auf unserer Website stellen.



Entsorgen Sie die Verpackung nicht, ohne sicherzustellen, dass die Pergola ordnungsgemäß funktioniert.



KARTON 1/4 (PFOSTEN UND LOSE TEILE))

REFERENZ	BILD	MENGE
A0		4

REFERENZ	BILD	MENGE
I0		4
J0		4
K0		1
L0		24
LO-1		25
M0		49
Q0		16
R0		16

REFERENZ	BILD	MENGE
S0		50
T0		16
U0		74
U0-3		1
W0		100
X0		49
X0-1		16
V0		25



REFERENZ	BILD	MENGE
Z0-1		1
Z0-2		1

REFERENZ	BILD	MENGE
Z0-5		1
Z0-6		1



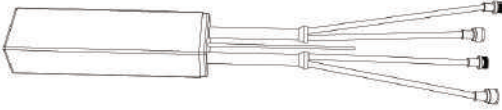

Z0-3		1
------	---	---

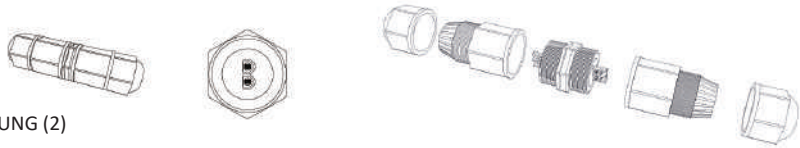
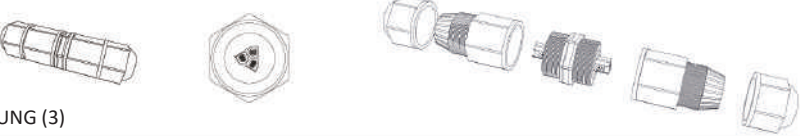
Z0-4		1
------	---	---

TEILE FÜR DIE MOTORISIERUNG

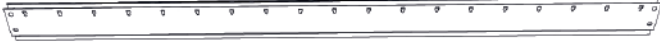
REFERENZ	BILD	MENGE
E-C	CONTROLLER 	1
E-R	REMOTE CONTROL 	1
E-P	KABEL (M15) 	1
E-W2	DICHTUNG (2) 	1
E-W3	DICHTUNG (3) 	1

KARTON 2/4 (PFOSTEN)

REFERENZ	BILD	MENGE
B0		1
B0-1		1
C0		1
C0-1		1
DO		2
F0		1

KARTON 2/4 (PFOSTEN)

REFERENZ	BILD	MENGE
E-T		1
TRANSFORMATOR		



ATTENTION!

Verbindungsstange (FO) und Bürste innen!
Bitte entfernen Sie die Verbindungsstange, bevor Sie mit der Montage fortfahren.



KARTON 3/4 (LAMELLEN)

REFERENZ	BILD	MENGE
GO		13

KARTON 4/4 (LAMELLEN)

REFERENZ	BILD	MENGE
GO		12

Die Aluminiumteile sind wie folgt: AO, BO, BO-1, CO, CO-1, DO, FO, GO, IO, KO, LO und LO-1.

Die Schrauben sowie die anderen Teile bestehen entweder aus Edelstahl, verzinktem Stahl, Kunststoff oder Nylon.

6. Notwendiges Werkzeug und Sicherheitsausrüstung (nicht beiliegend)



Schutzbrille & Handschuhe



2x Leiter



Elektrische Bohrmaschine
+ 12mm Betonbohrer



Pistolenbohrer

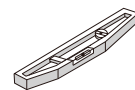

Wasserwaage

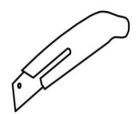

Allzweckmesser



Helm

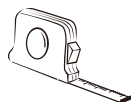

Bandmaß



Schraubenschlüssel

7. KONTAKT

Wir sind für Sie da, wenn Sie Fragen haben.

Email: service@heimundgarten24.de

Tel: +49 (0) 821 79500 001

8. MONTAGEPLAN (Abmessungen in mm)

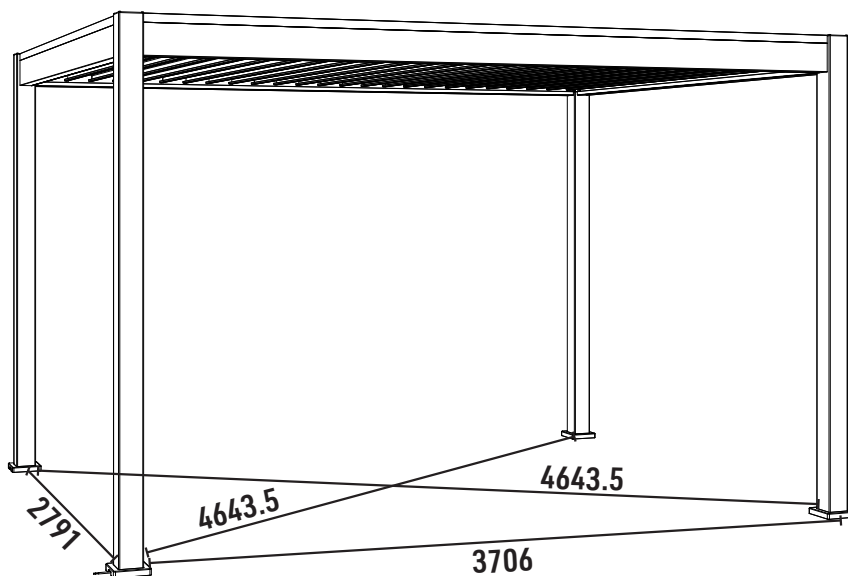
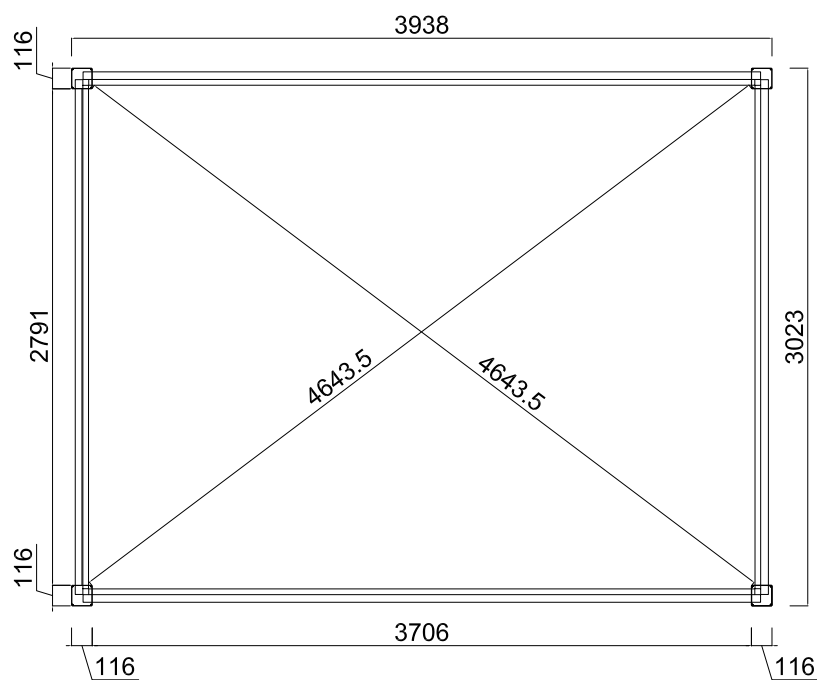

9. MONTAGESCHRITTE

- Schritt 1:** Rahmen und Pfosten
- Schritt 2:** Elektrische Installation
- Schritt 3:** Montage der Lamellen
- Schritt 4:** Abschluss und Befestigung



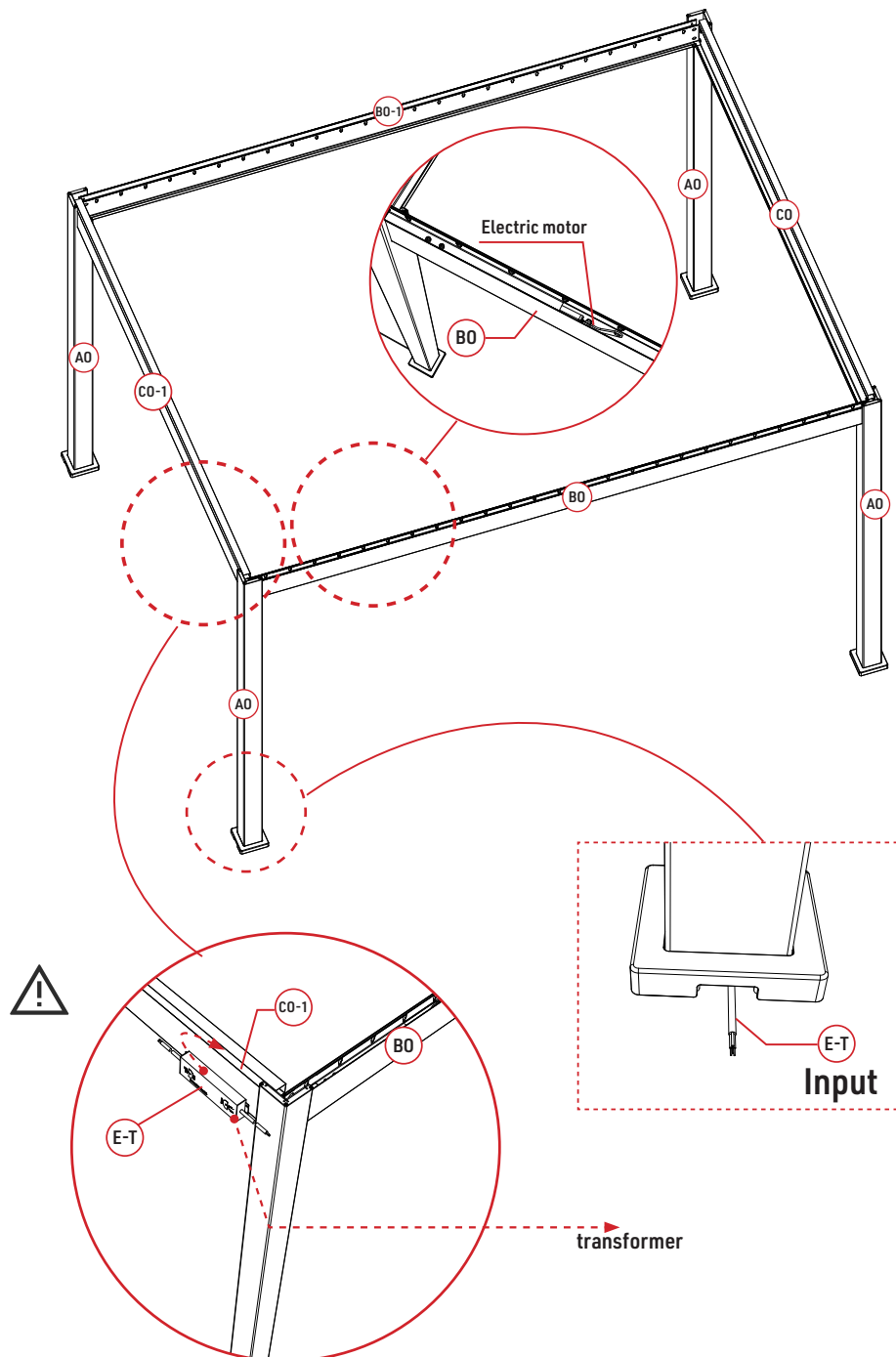

Um Beschädigungen Ihrer Pergola während des Montageprozesses zu vermeiden, empfehlen wir Ihnen, diese auf einem Tisch, auf Böcken oder auf einer ebenen und sauberen Oberfläche zusammenzubauen.



Schritt 1



Da die Pergola motorisiert ist, befindet sich der Motor im vorderen Balken **BO**. Das Stromkabel verläuft durch den Pfosten **AO**, der sich links vom Balken **BO** befindet. Der Transformator befindet sich im Balken **CO-1** und sollte wie auf dem Schema zu sehen links vom Balken **BO** installiert werden.

Schritt 1

A0		4
IO		4
	XO-1 	16
JO		4

ZO-1		1
ZO-2		1



A0 x4

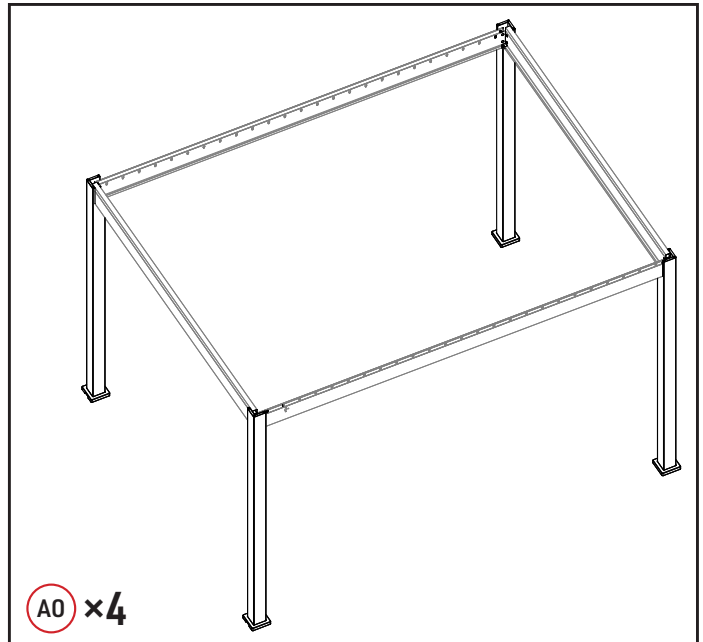

Schieben Sie die **IO**-Abdeckungen auf die Pfosten **A0**, wobei die Öffnung in dieselbe Richtung zeigt wie die Öffnung am halbmond-förmigen Pfosten. Wie auf dem Schema dargestellt. Befestigen Sie dann die **JO**-Platine mit den Schrauben **XO-1** unter Verwendung eines Schraubenziehers und des Bits **ZO-2**. Beginnen Sie mit leichtem Anziehen und ziehen Sie dann vollständig an, sobald alle Schrauben positioniert sind.

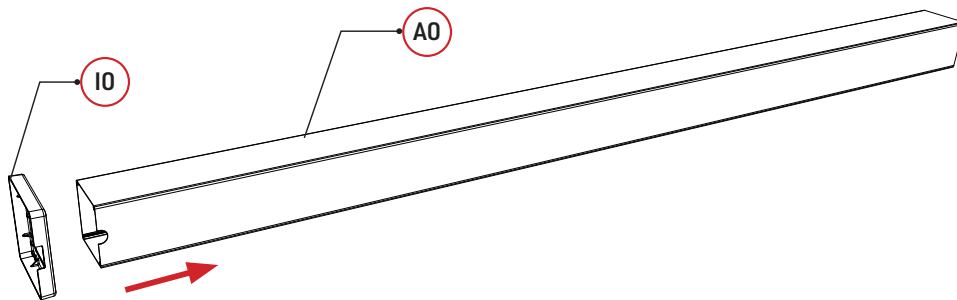

1.

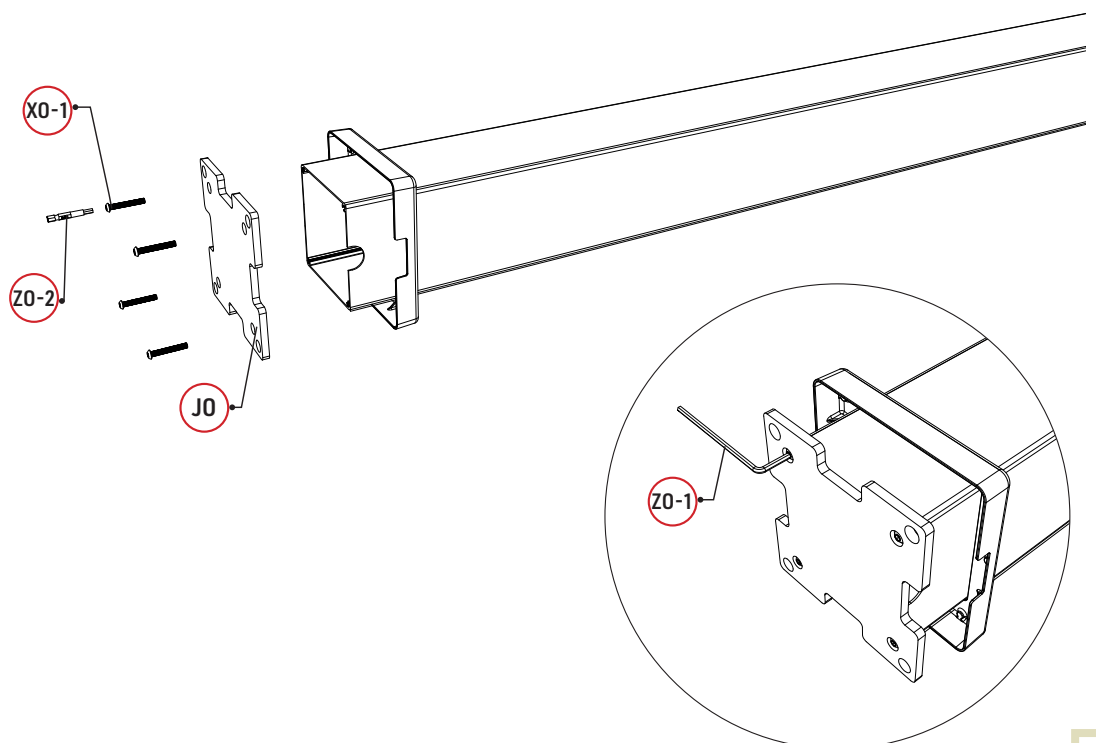

2.



Schritt 1

BO		1
BO-1		1
DO		2

Trennen Sie die Erweiterungen DO von den Balken BO und BO-1. Bewahren Sie die entfernten Teile für später auf.

1.

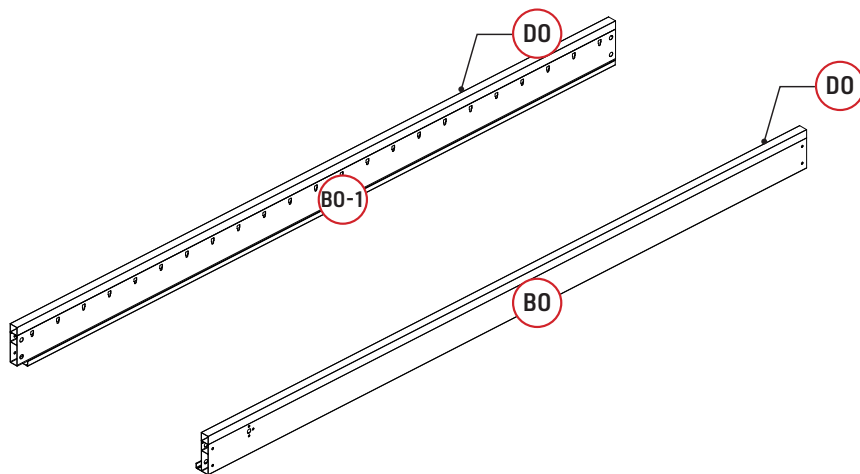

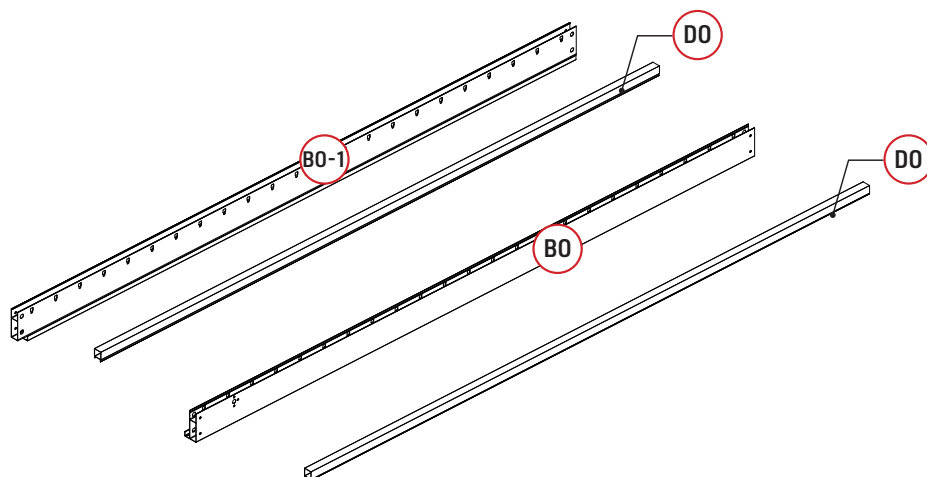

2.



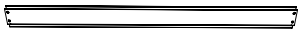
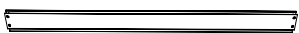

Schritt 1

CO		1
CO-1		1

E-T	 Transformer	1
-----	--	---

Q0		8
----	---	---

Z0-3		1
Z0-4		1

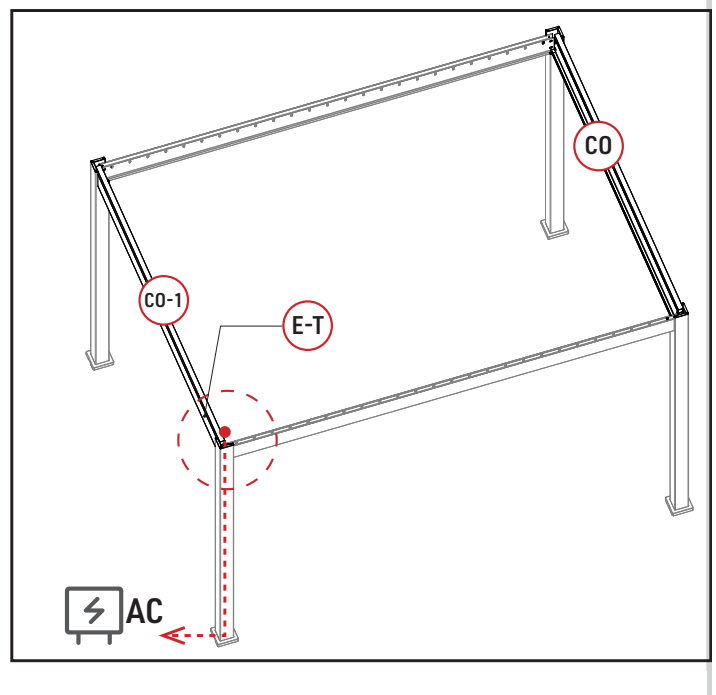

Führen Sie den Transformator **E-T** gemäß der Abbildung in den Balken **CO-1** ein. Lassen Sie die Output- und Input-Teile aus dem Balken herausragen.

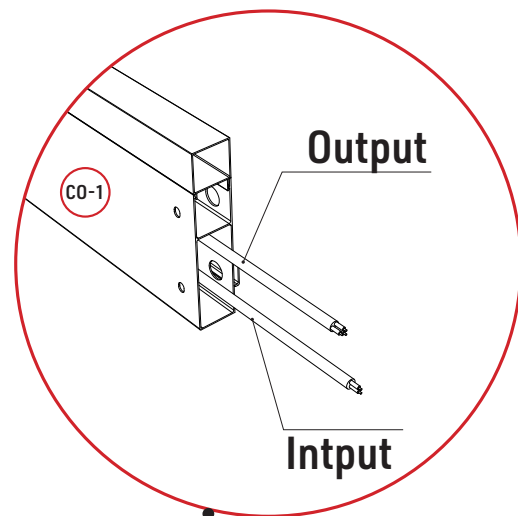
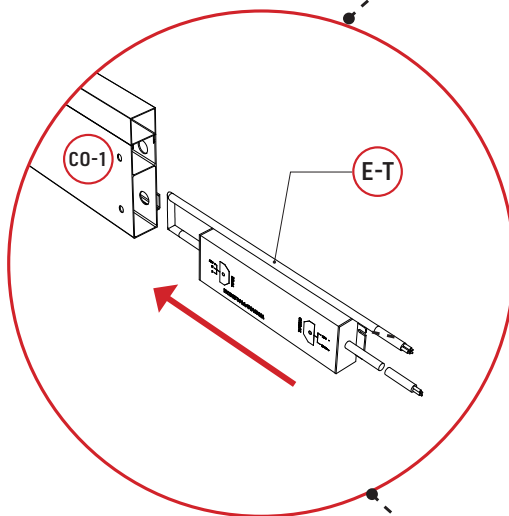
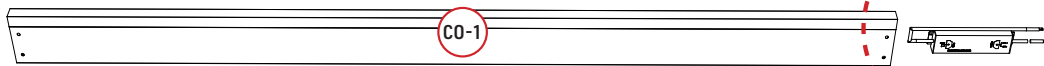

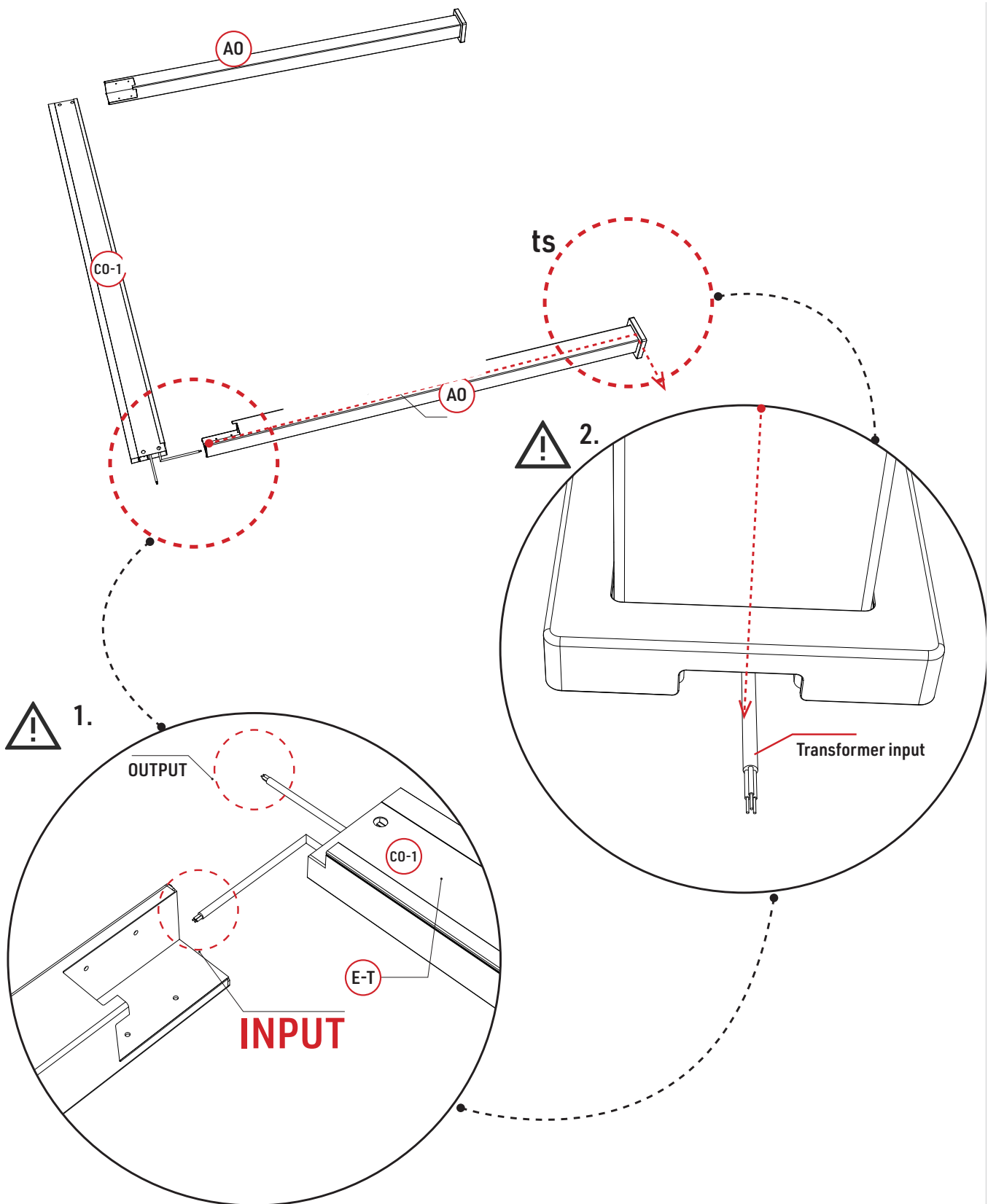



Setzen Sie den Balken **CO-1** in die Pfosten **AO** ein. Führen Sie das INPUT-Kabel des Teils **E-T** in den Pfosten **AO** ein und lassen Sie es durch die Wasserablauföffnung herausragen.

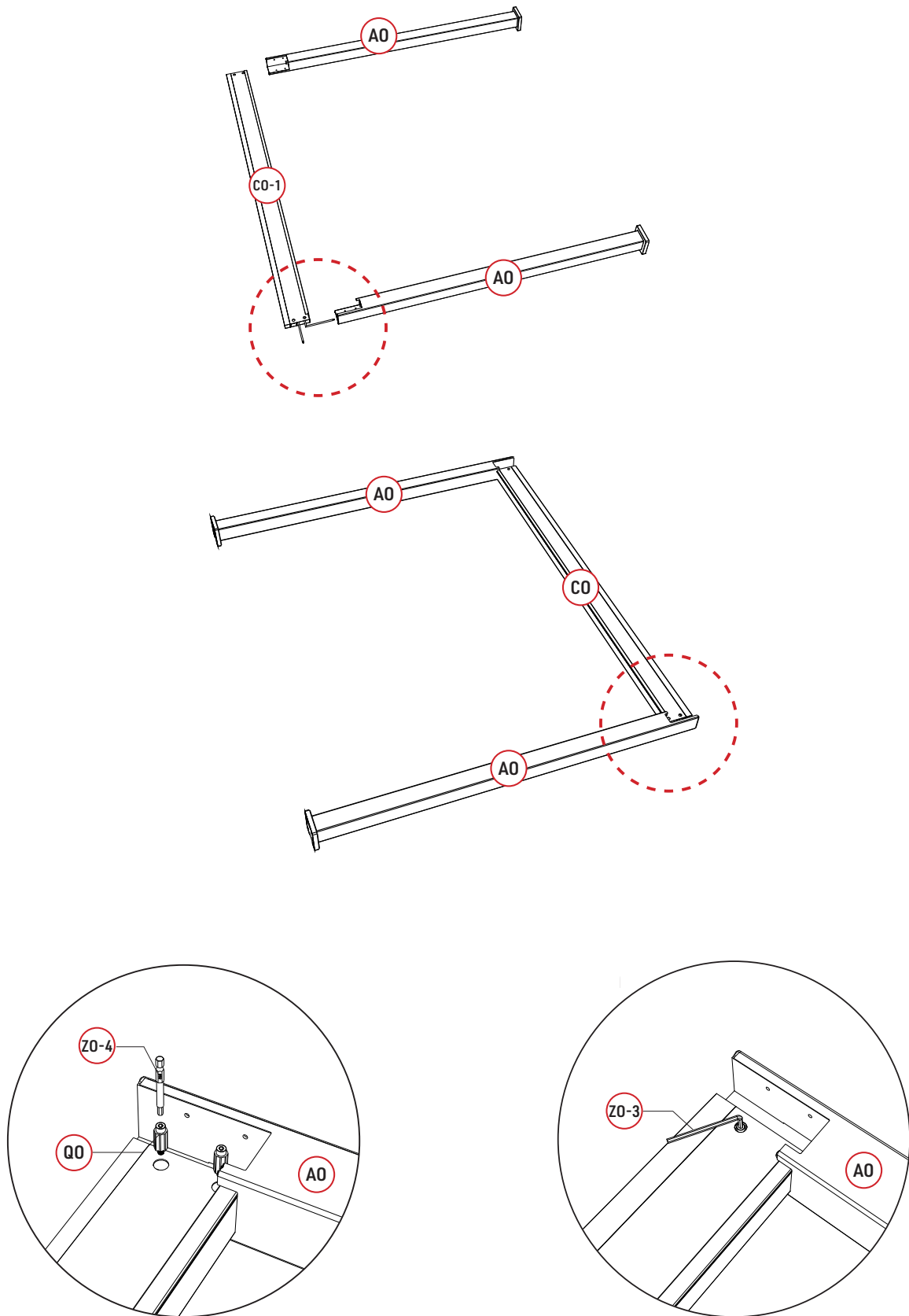

Befestigen Sie den Balken **CO-1** an den Pfosten **AO** auf jeder Seite mit den Schrauben **QO**, unter Verwendung eines Schraubenziehers und des Bits **ZO-4** oder **ZO-3**.



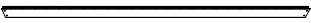

Wiederholen Sie den Vorgang, um den Balken **CO** an den Pfosten **AO** zu befestigen.

Schritt 1

B0		1
B0-1		1

Q0			8
----	---	---	---

Z0-3		1
Z0-4		1

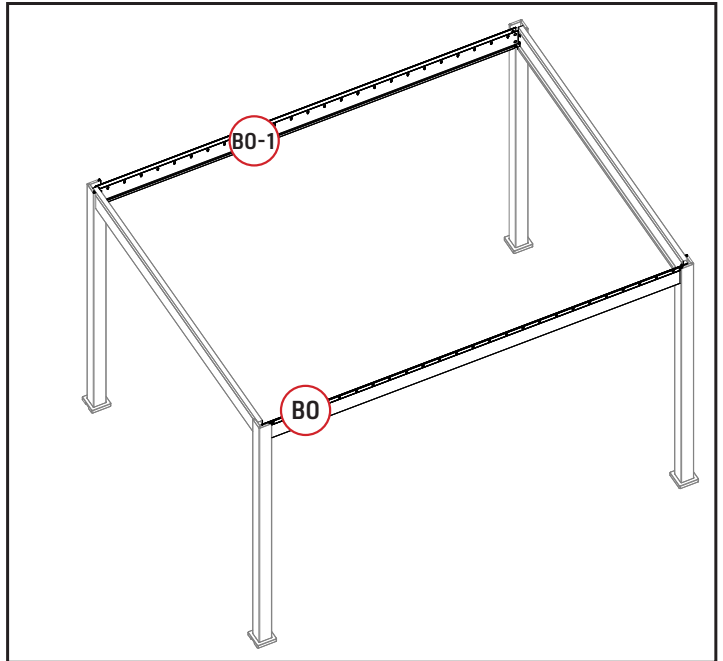

Mit 2/3 Personen (eine, die die Struktur hält, eine für die Installation zuständig ist und eine für die Unterstützung bei der Installation), setzen Sie die Balken **B0** und **B0-1** auf die Pfosten **AO** ein, wie auf dem Schema angezeigt, und befestigen Sie die Balken mit den Schrauben **Q0** unter Verwendung eines Schraubenziehers und des Bits **Z0-4** oder **Z0-3**.

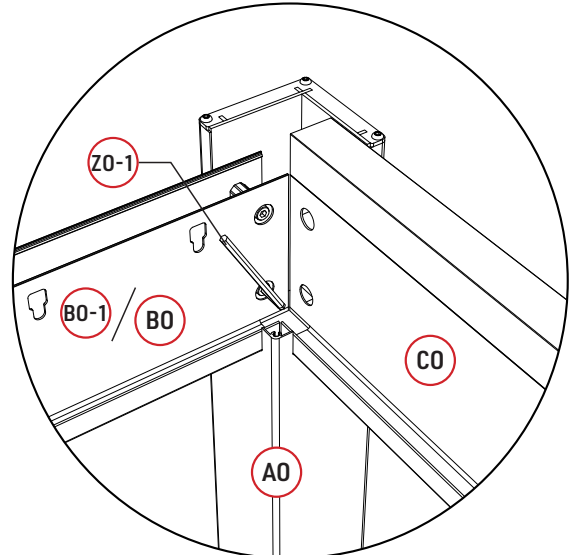
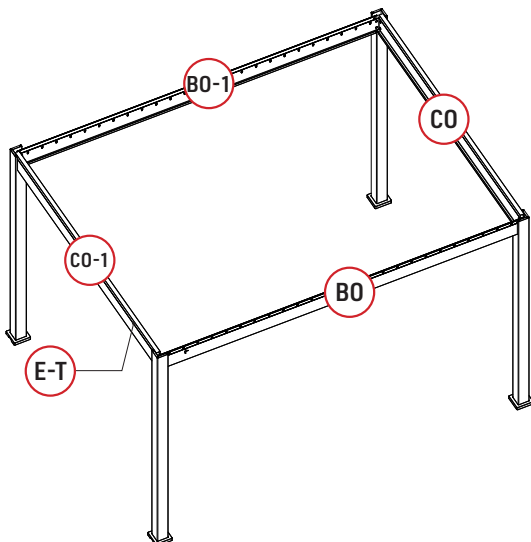
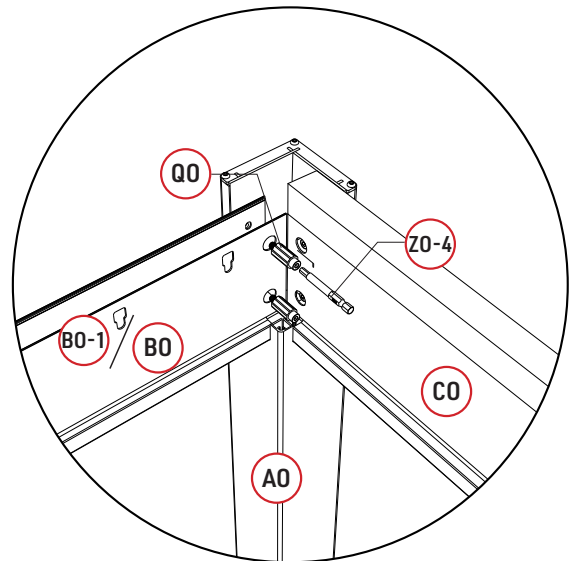
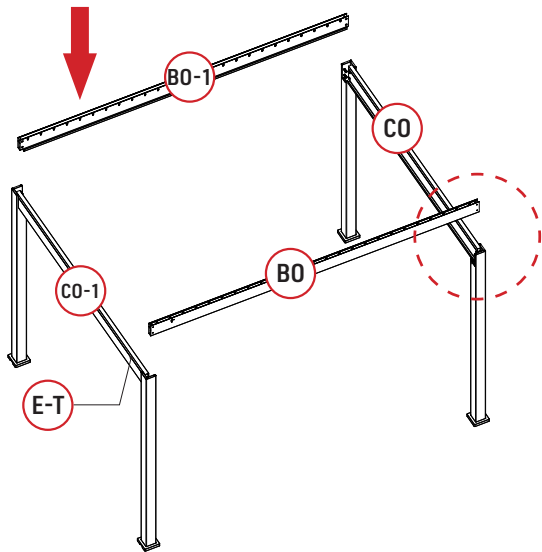

Führen Sie den Controller **EC** in den Balken **BO** ein. Stellen Sie sicher, dass das Kabel **E-T** weiterhin aus dem Pfosten **AO** herausragt.

Schritt 2

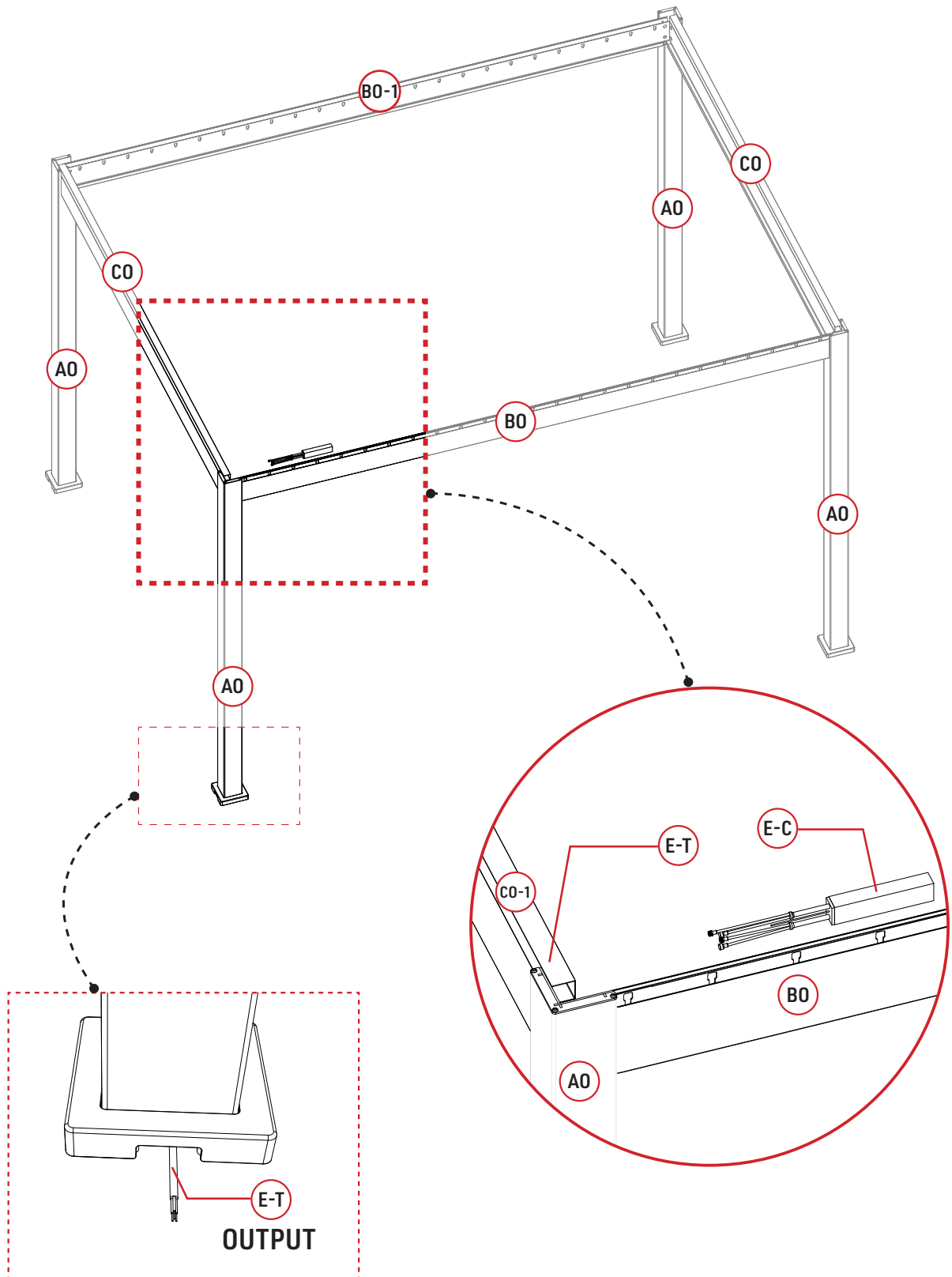

Hier sind die verschiedenen elektrischen Elemente, die Ihren Anschluss bilden.

Schritt 2

Controller

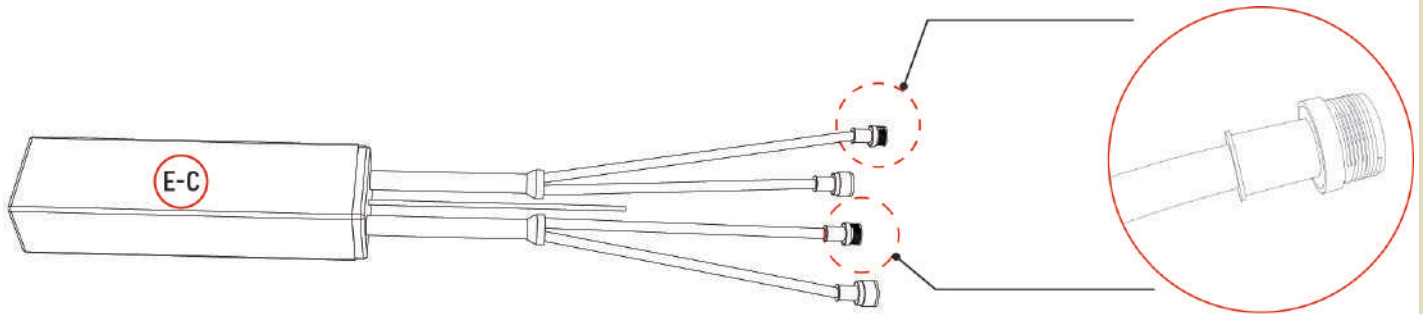

Transformator

	MODEL:H-PF-24V400W	IP67 CE RoHS FC ENEC	
PRODUCT:LED CONVERTER INPUT:100~265V~4.5A 50/60Hz 400W OUTPUT:24V=16.6A(16.6A@50°C) PF:0.95max EF:0.95 ta/tc:-40°C-50°C/75°C		Use within the specified rating. Wired accurately after verifying wiring diagram. Ground the earth terminal to prevent electrocution during the. Installation with the space of 50mm or more in between. Certainly install after reading the installation manual on.	MADE IN CHINA

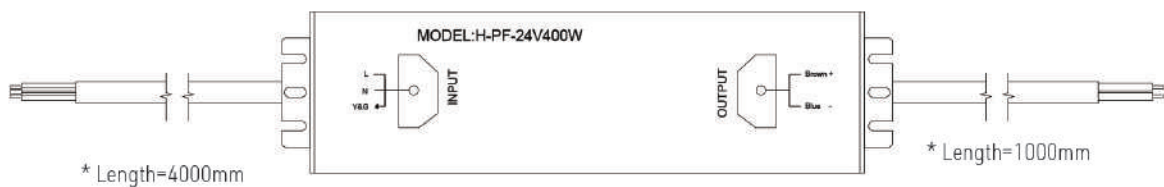

Schritt 2

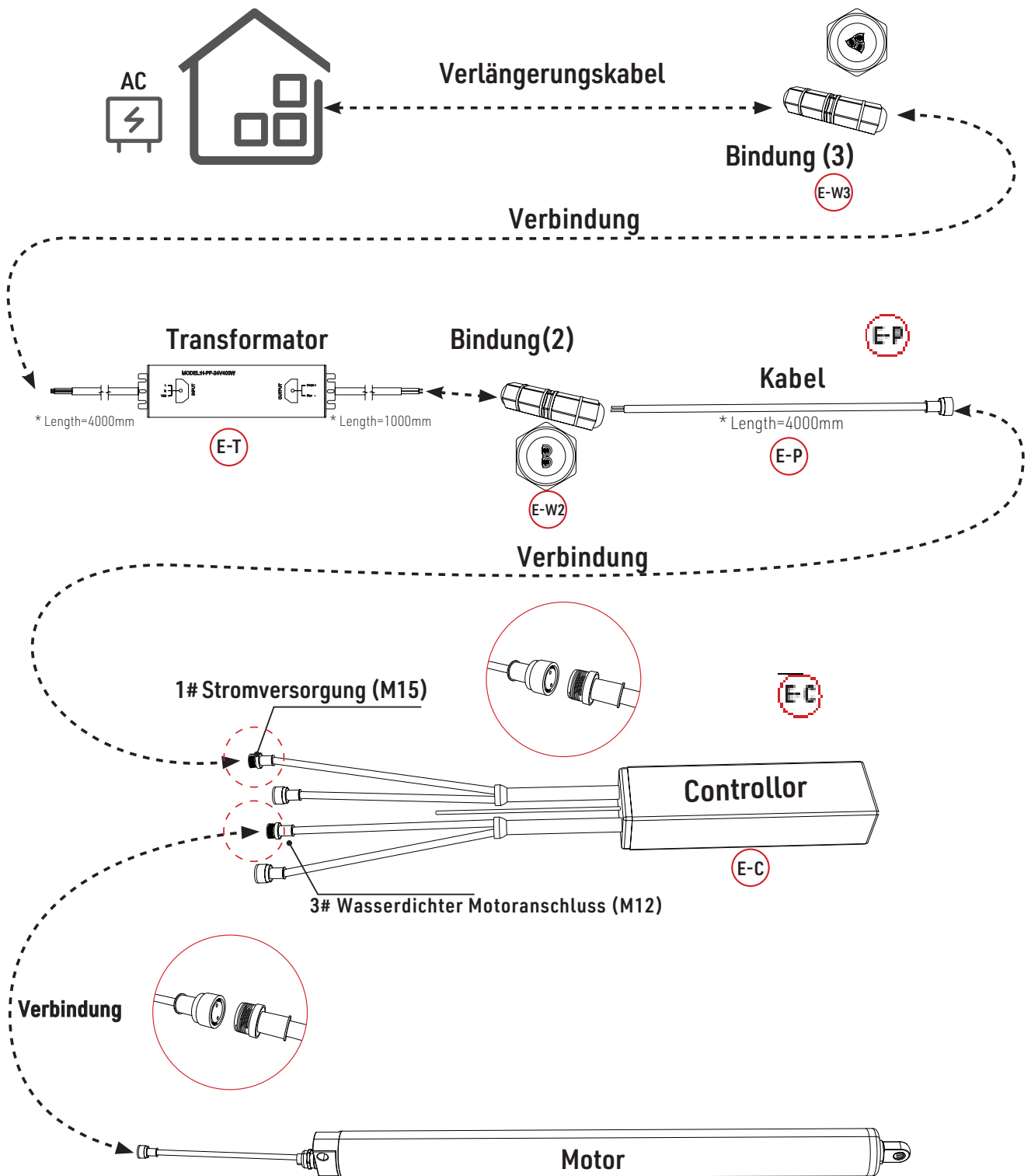

Führen Sie die elektrischen Anschlüsse wie folgt durch:

Verbinden Sie den Motor in Balken **BO** mit dem Controller **E-C** über die entsprechende Verbindung, Der Controller muss mit dem Stromkabel **E-P** und dann mit dem wasserdichten Verbindungsstück (2) **E-W2** verbunden werden.

Setzen Sie die Verbindung fort, indem Sie das Verbindungsstück **E-W2** mit dem Transformator **E-T** verbinden.

Fügen Sie das wasserdichte Verbindungsstück (3) **E-W3** zum Transformator **E-T** hinzu, Schließen Sie die Installation durch Anschluss an Ihr Haus ab.

Installation des LED-Kits

Schritt 1:

Die LED werden direkt an den Regenrinnen an den Balken angebracht, wie auf dem Schema dargestellt..

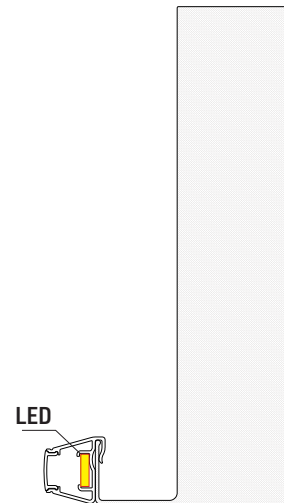

Beachten Sie die Anweisungen der motorisierten Pergola und stellen Sie sicher, dass der Transformator und der Stecker korrekt positioniert sind.

Schritt 2:

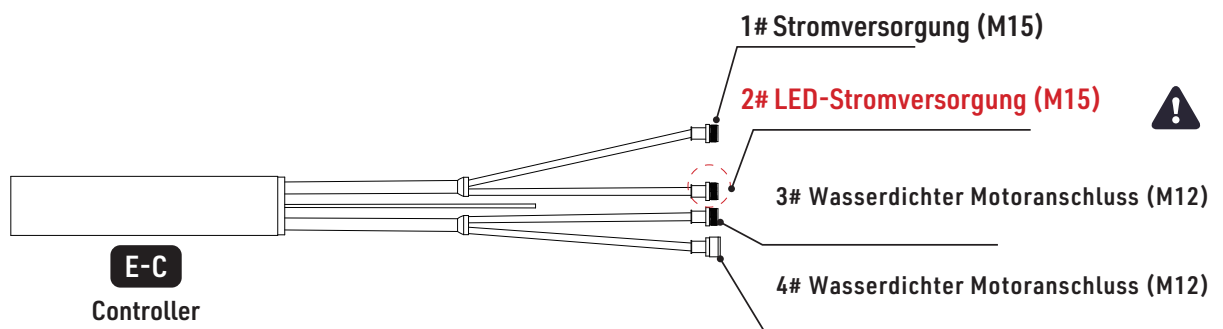

Schließen Sie den LED-Controller **L-C1** einerseits an den Pergola-Controller **E-C** an und verbinden Sie den **L-C1**-Controller andererseits mit dem LED-Kabel, wie auf dem Schema angezeigt.

Schritt 3:

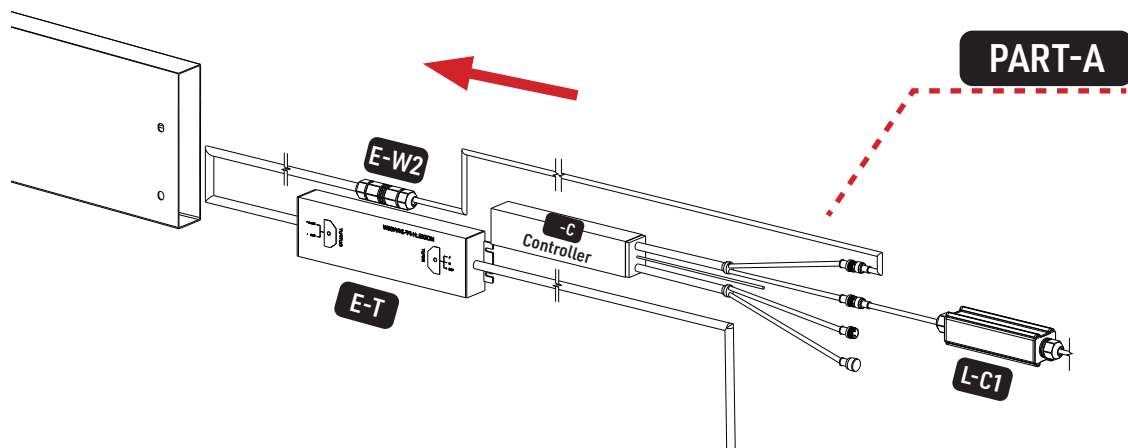

Nachdem Sie den Controller **LC-1** mit dem Controller **E-C** verbunden haben, platzieren Sie das gesamte Set in der Hohlräum der Balken.

Schritt 4:

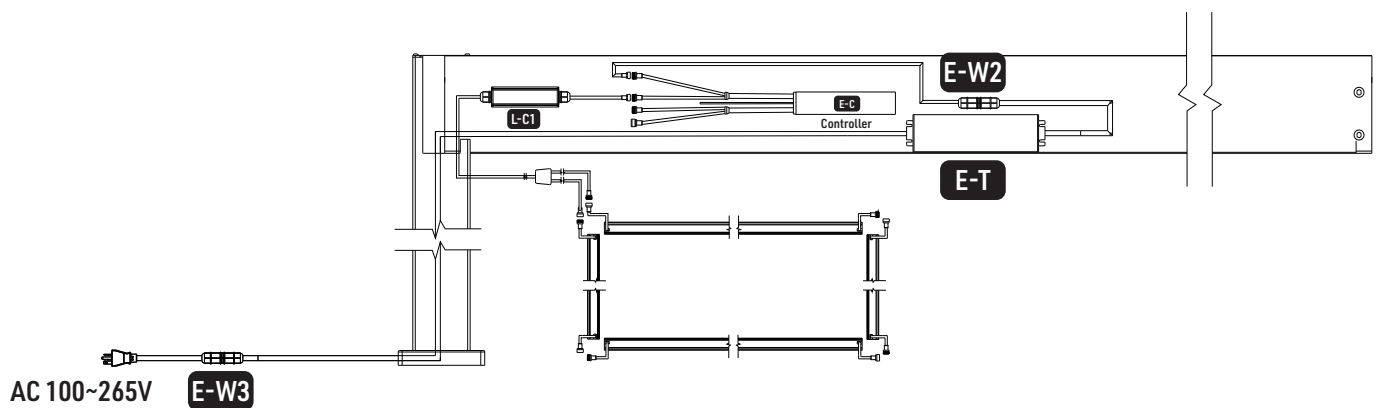

Das "Input"-Kabel des Transformators verläuft durch den Pfosten und tritt durch die Wasserablauföffnung des Pfostens aus, um mit der Hausstromversorgung verbunden zu werden. Der "Output"-Teil des LED-Controllers muss mit dem LED-Kabel verbunden werden.

VERBINDUNG MIT DER APP



Die Beleuchtung der Pergola funktioniert über eine App.

Bitte laden Sie die App Tuya Smart oder Smart Life (abhängig vom Land, in dem Sie sich befinden) aus dem App Store oder Google Play herunter.

Schritt 1:

Drücken Sie die Match/Set-Taste und halten Sie sie 2 Sekunden lang gedrückt, oder drücken Sie die Match/Set-Taste zweimal schnell hintereinander, um die vorherige Netzwerkverbindung zu löschen und in den Smart-Modus zu wechseln.

Schritt 2:

Wiederholen Sie das Ein- und Ausschalten fünf Mal hintereinander, um auch die vorherige Netzwerkverbindung zu löschen, und wechseln Sie dann in den Smart-Konfigurationsmodus, wobei die LED erneut 10 Mal blinken wird.

Wenn die Verbindung zur Tuya-App erfolgreich hergestellt wurde, hört die LED auf, violett zu blinken, und wechselt zu rot.

BENUTZEROBERFLÄCHE DER TUYA-APP

BENUTZEROBERFLÄCHE DES WEIßEN LICHTS:

Berühren Sie den Schieberegler, das weiße Licht wird angezeigt und Sie können dann die Helligkeit einstellen.

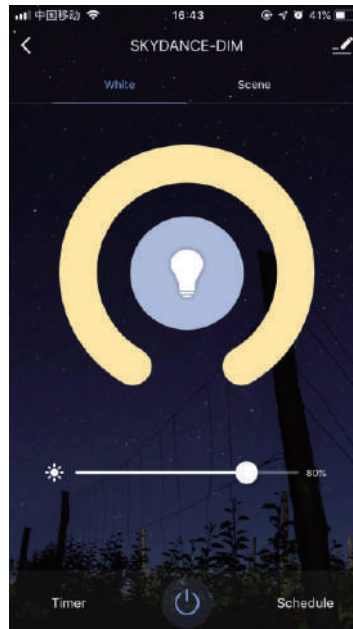

BENUTZEROBERFLÄCHE DER FARBLICHTER:

Berühren Sie den Kreis, um die Farbe auszuwählen. Verwenden Sie dann den ersten Schieberegler, um die Helligkeit einzustellen, und den zweiten, um die Farbsättigung anzupassen (um einen Farbverlauf von der gewählten Farbe zum Weiß zu erzeugen).

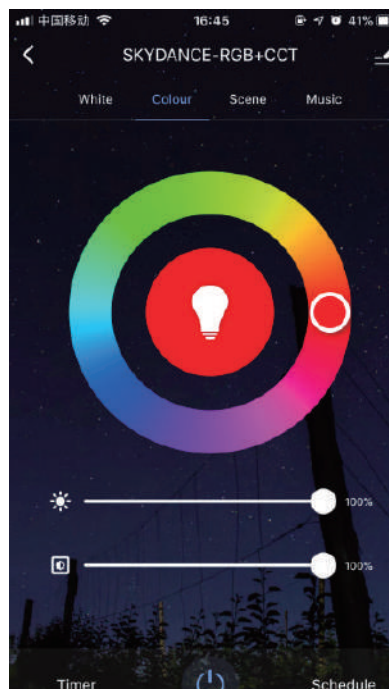



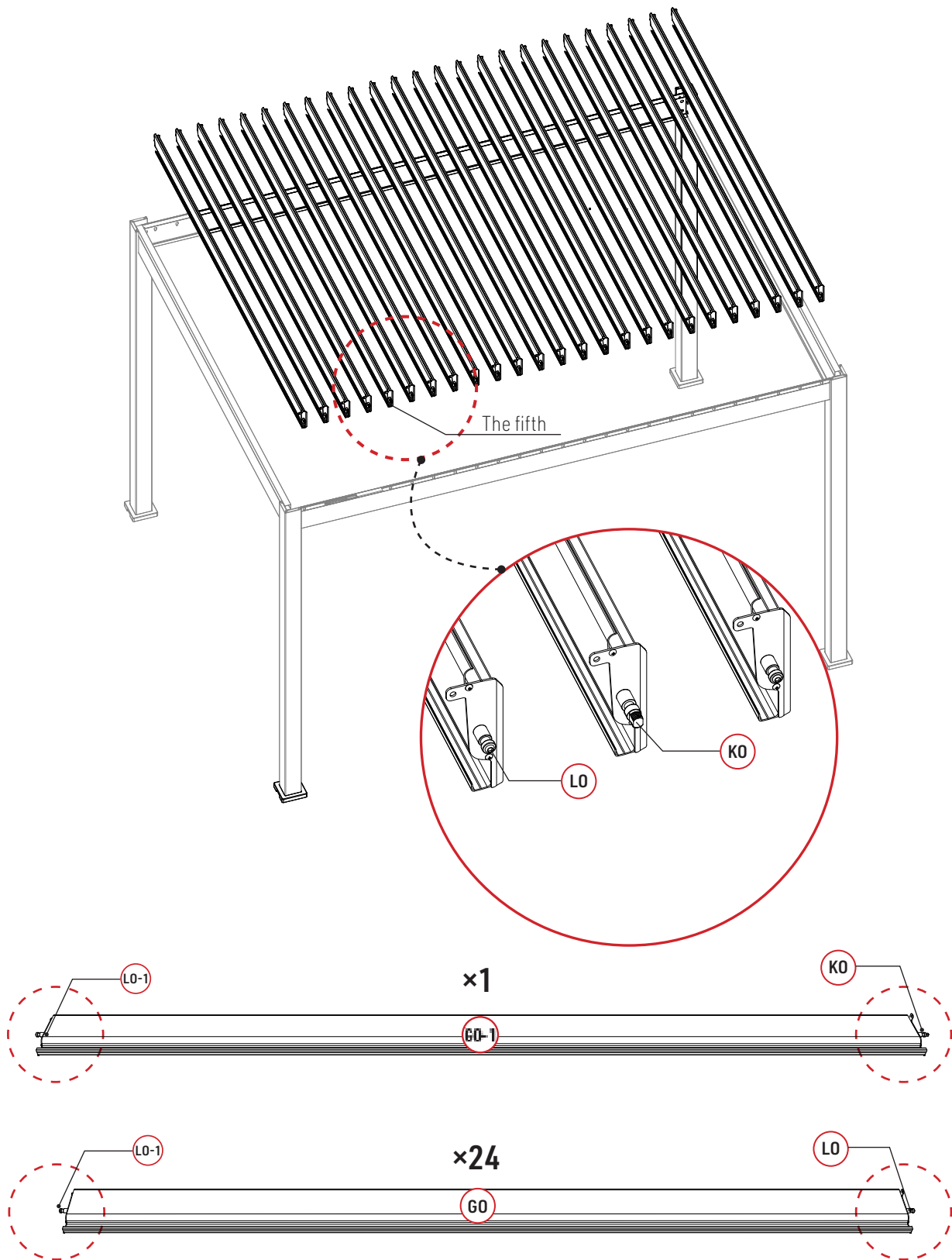



Schritt 3



Die Pergola besteht aus 25 Lamellen: 24 **GO**-Lamellen und 1 **GO-1**-Lamelle, die sich von den anderen unterscheidet und die Hauptlamelle sein wird. Die fünfte Lamelle von links ist Ihre Hauptlamelle **GO-1**, diese Lamelle wird direkt mit dem Motor verbunden.

Schritt 3

LO		24	XO		49
LO-1		25	UO		49
MO		49			

ZO-1		1
ZO-2		1



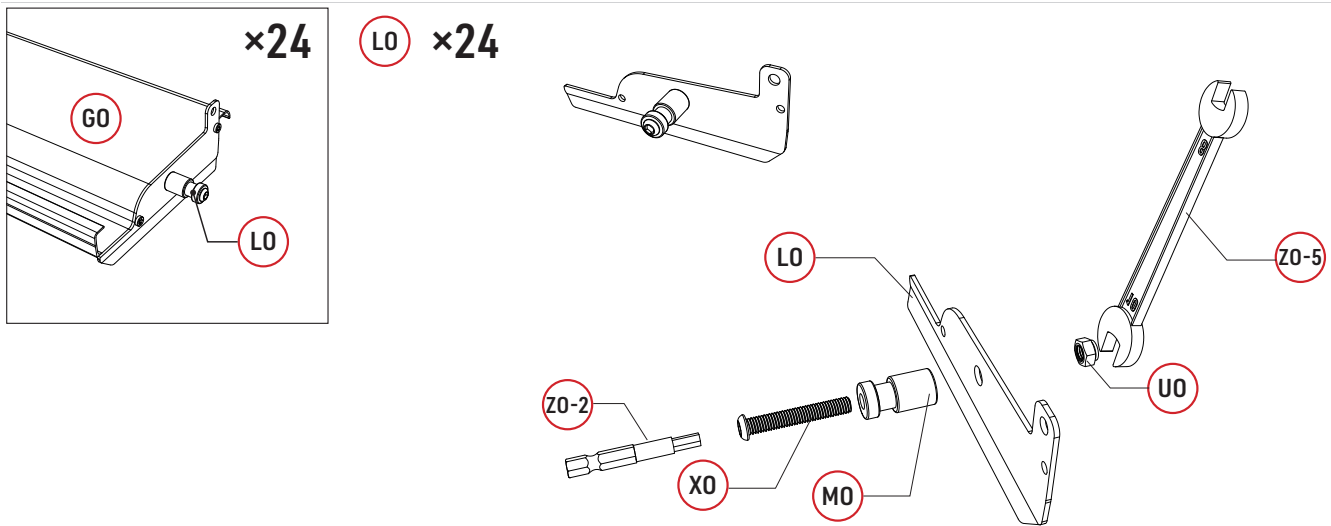

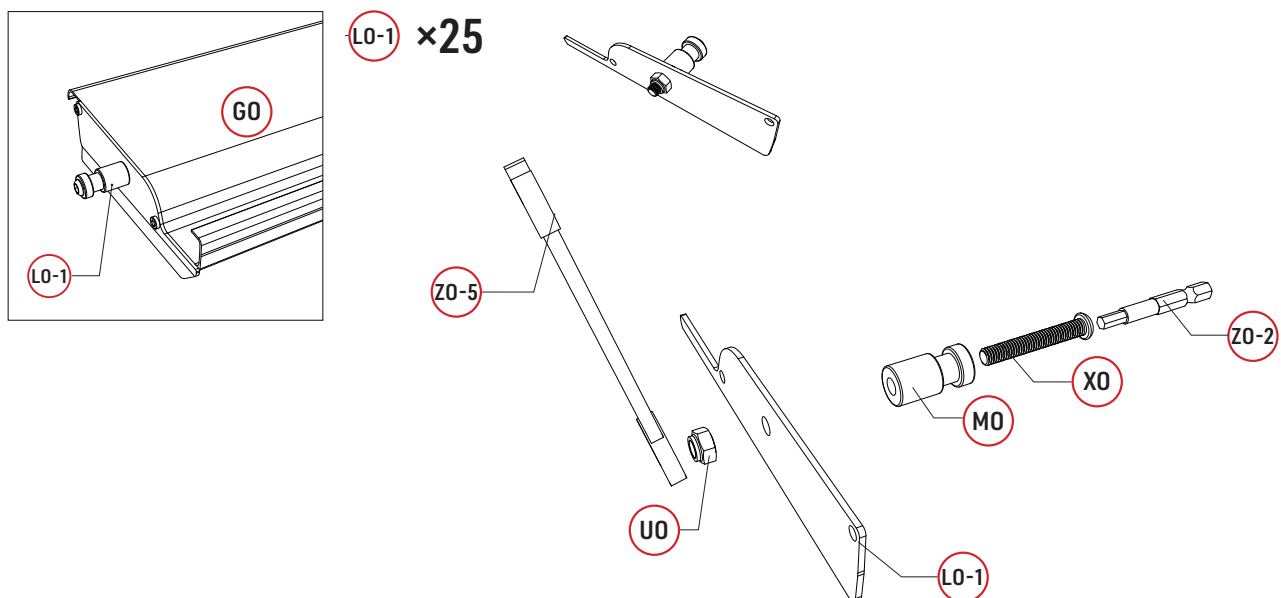

Das Stiftstück entsprechend den Teilen **XO**, **MO** und **UO** in den Lamellenabdeckungen **LO** und **LO-1** zusammenstellen und befestigen. Sicherstellen, dass das Stiftstück richtig ausgerichtet ist, sowohl für das Teil **LO** als auch für das Teil **LO-1**, wie im Schema angegeben.





Verwenden Sie einen Schraubendreher und den Aufsatz **ZO-2**, um das Einsetzen der Schraube **XO** in die Mutter **UO** zu erleichtern. Um Verletzungen zu vermeiden und den Vorgang nicht zu erschweren, empfehlen wir, die Mutter während dieser Manipulation mit dem Schlüssel **ZO-5** zu halten.



Schritt 3

GO		25
KO		1
LO		24
LO-1		25
WO	 	100

ZO-1		1
ZO-2		1
ZO-6		1

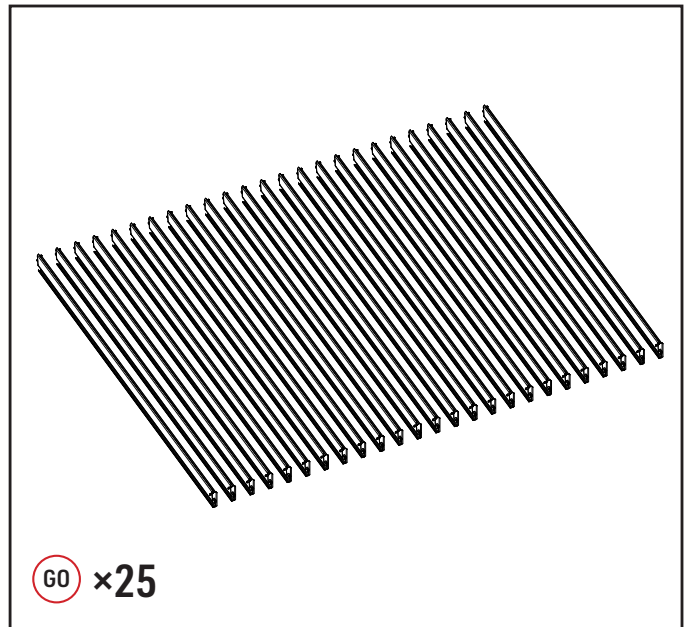

Um Ihre **GO-1**-Lamelle zusammenzustellen, befestigen Sie die Lamellenabdeckung **KO** rechts und **LO-1** links. Verwenden Sie die Schrauben **WO**, und benutzen Sie den Schraubendreher **ZO-6**, wie im Schema angegeben.

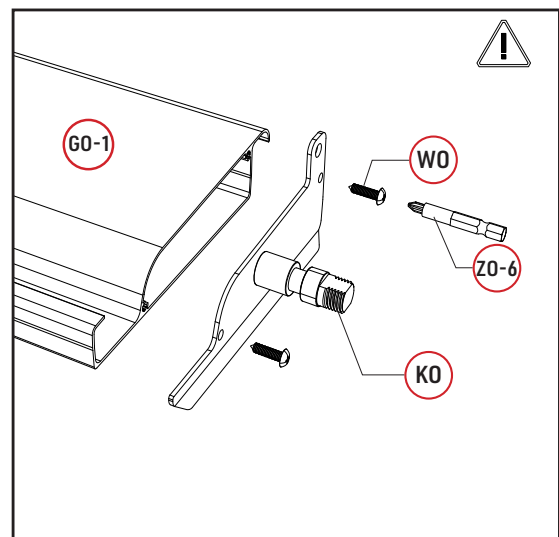
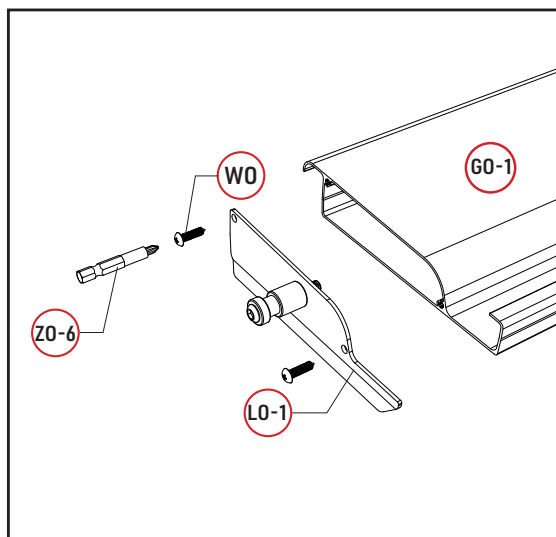
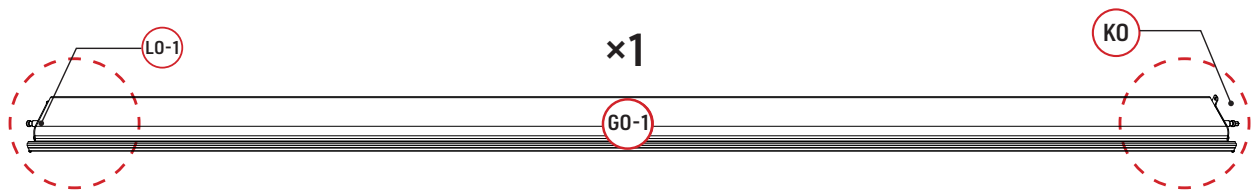

Setzen Sie den Stift entsprechend den Teilen **XO**, **MO** und **UO** in die Lamellenabdeckungen **LO** und **LO-1** zusammen und befestigen Sie ihn. Stellen Sie sicher, dass der Stift sowohl für das Teil **LO** als auch für das Teil **LO-1** in der richtigen Richtung installiert ist, wie im Schema angegeben.

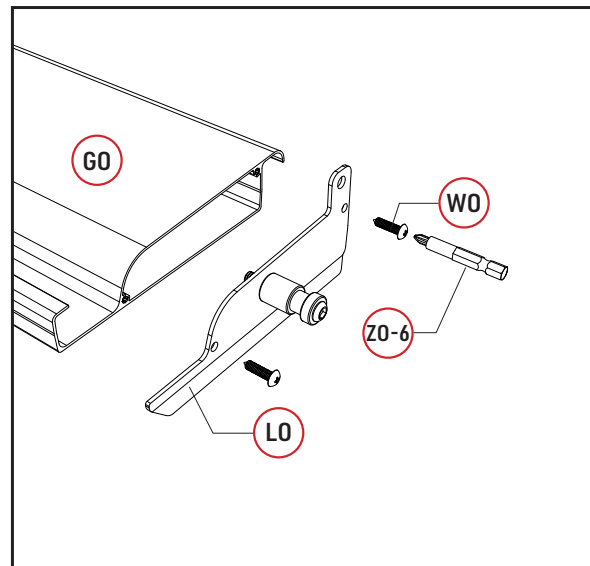
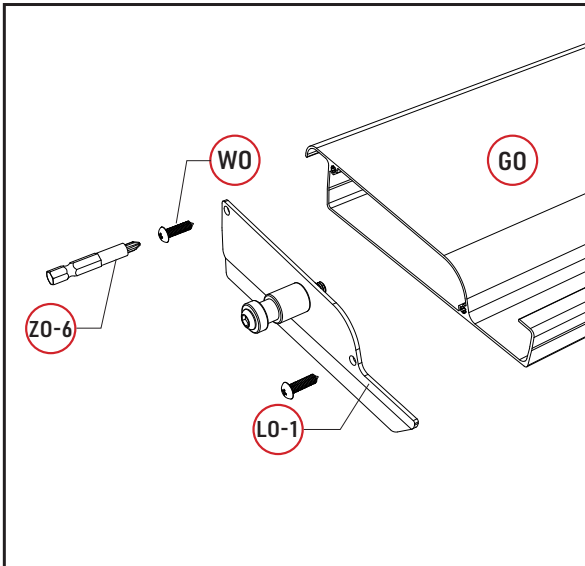
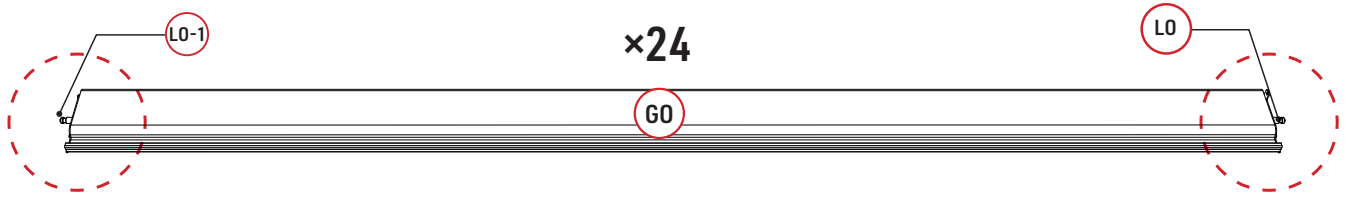

Schritt 4

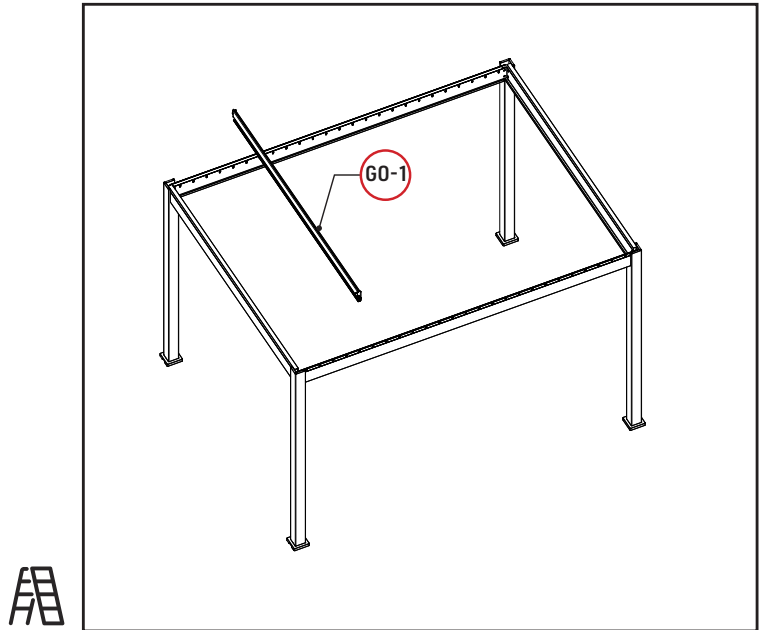

Setzen Sie die Hauptlamelle an der fünften Position von links auf den Balken **BO** ein. Die Lamellenabdeckung **KO** muss auf der Seite des Balkens **BO** installiert werden.

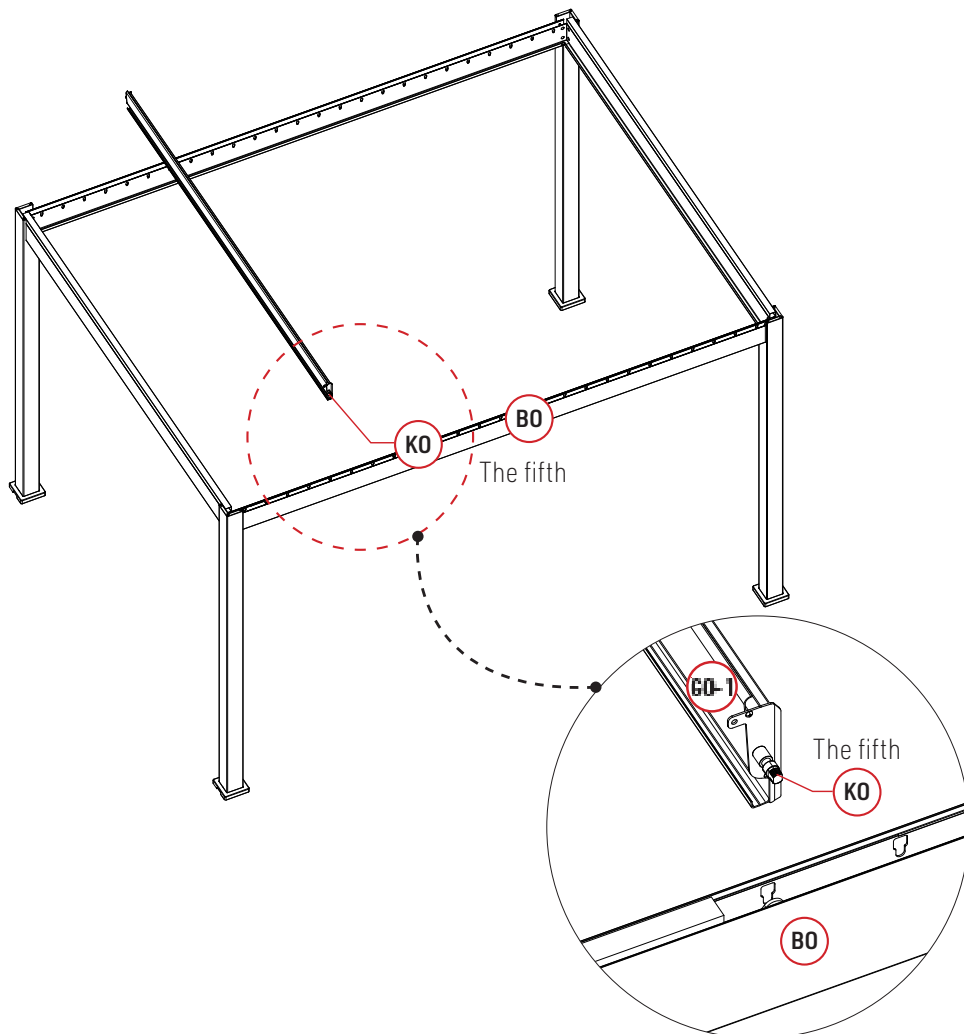

1

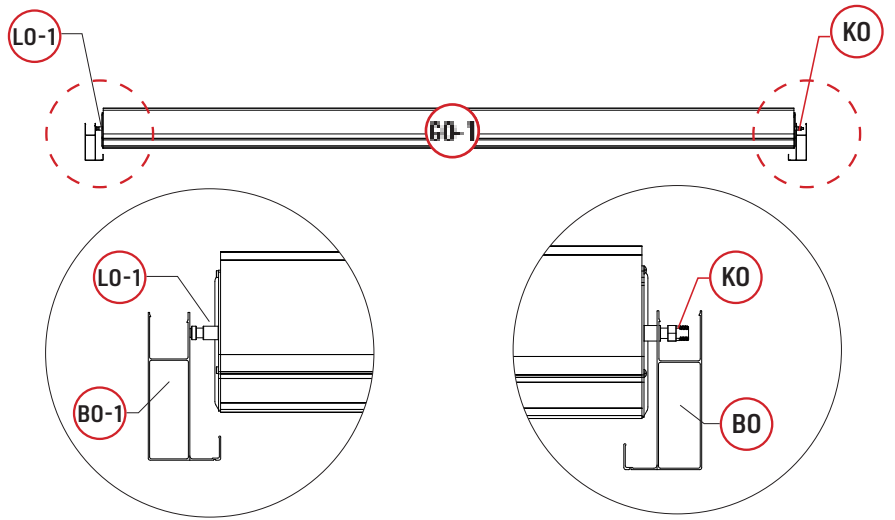
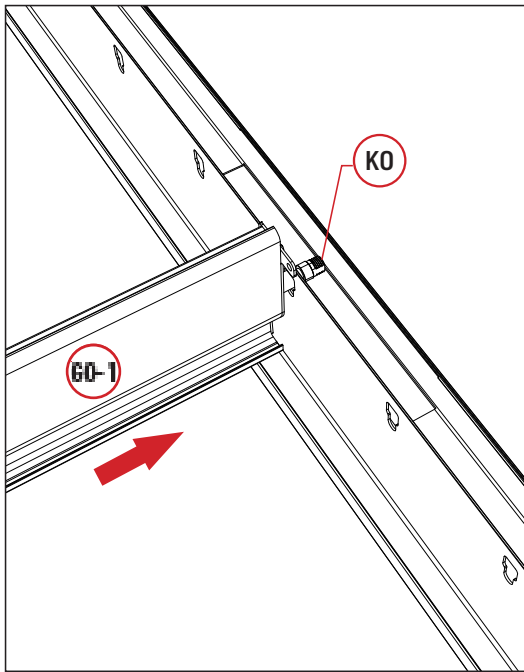

2

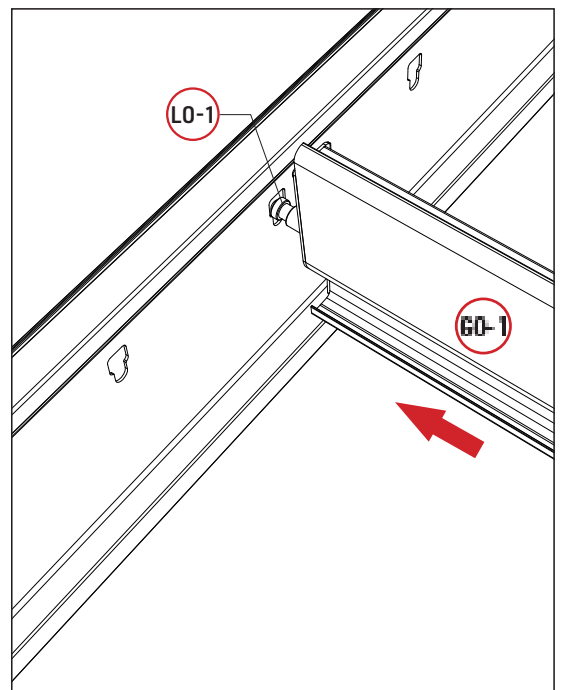
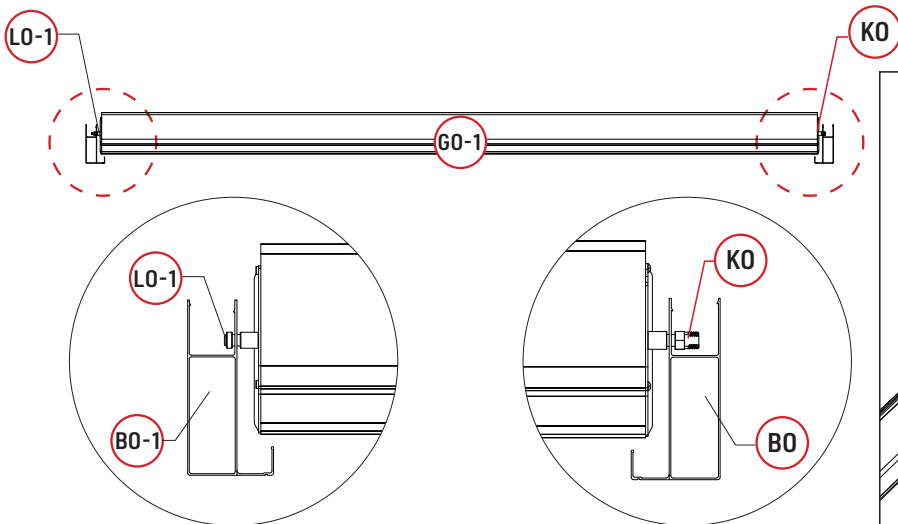

Schritt 4

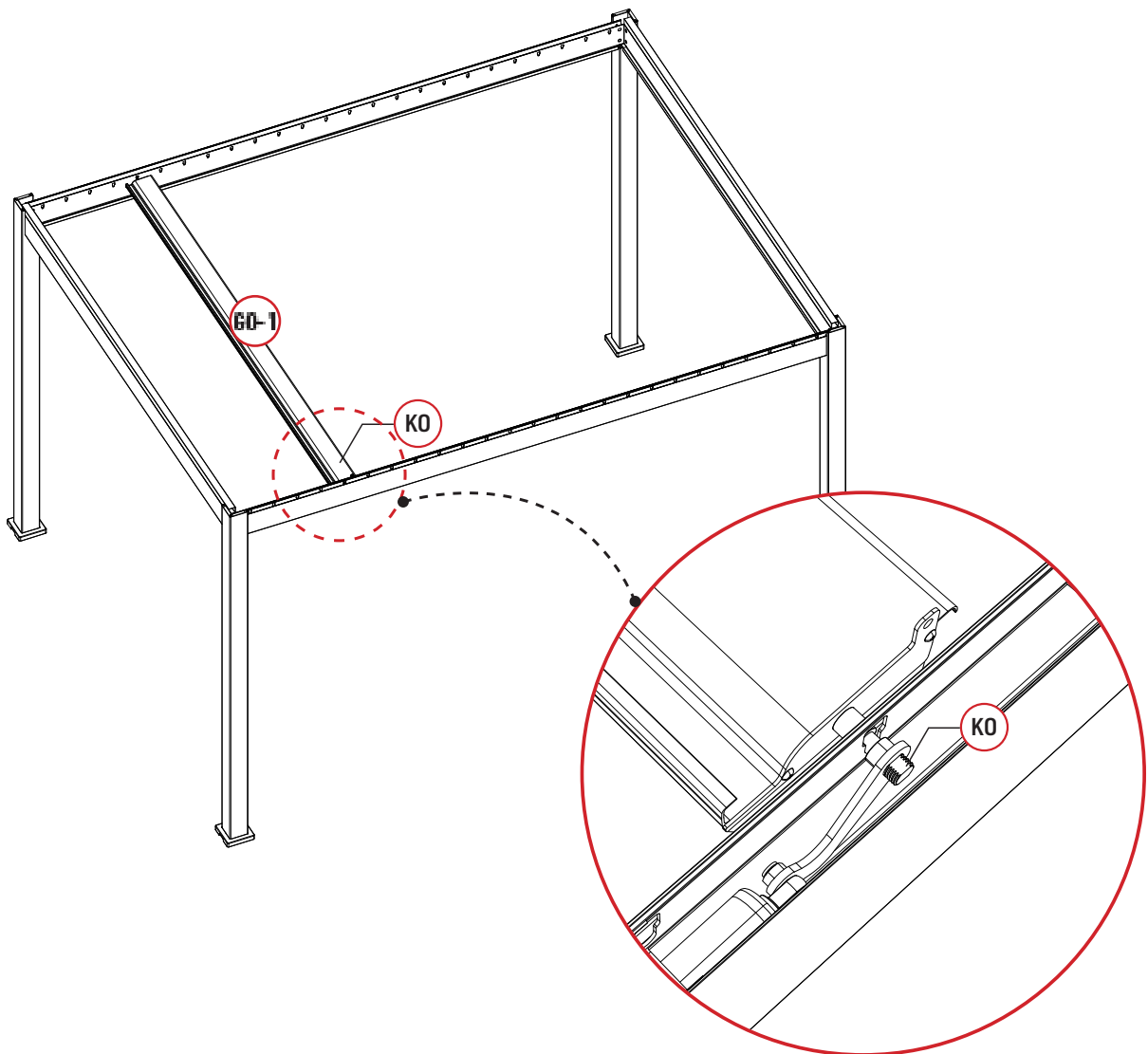
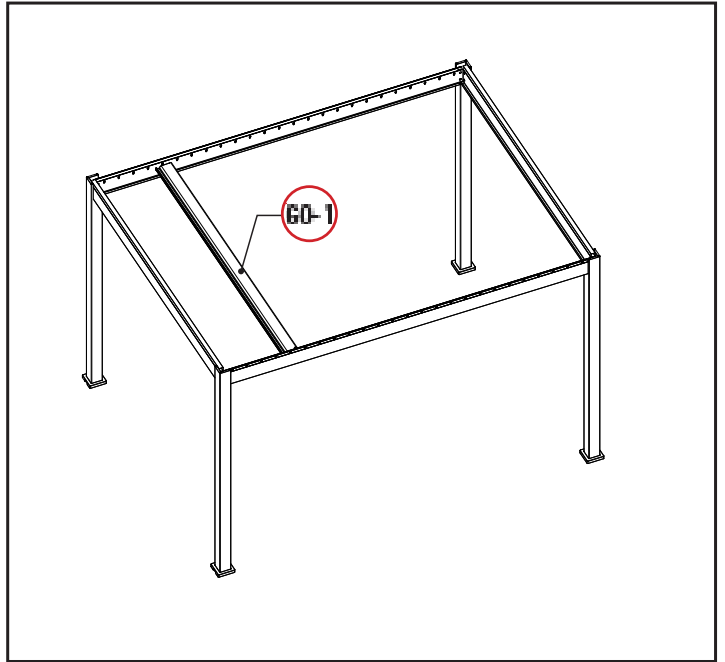

Lösen Sie die Schrauben auf dem Balken **BO** mit dem Inbusschlüssel **ZO-3**, um den Motorarm in den Stift der Lamellenabdeckung **KO** einzuführen, und schrauben Sie dann die Mutter **UO-3** mit einem Schraubenschlüssel fest. Ziehen Sie die zuvor gelösten Schrauben mit dem Inbusschlüssel **ZO-3** wieder an.

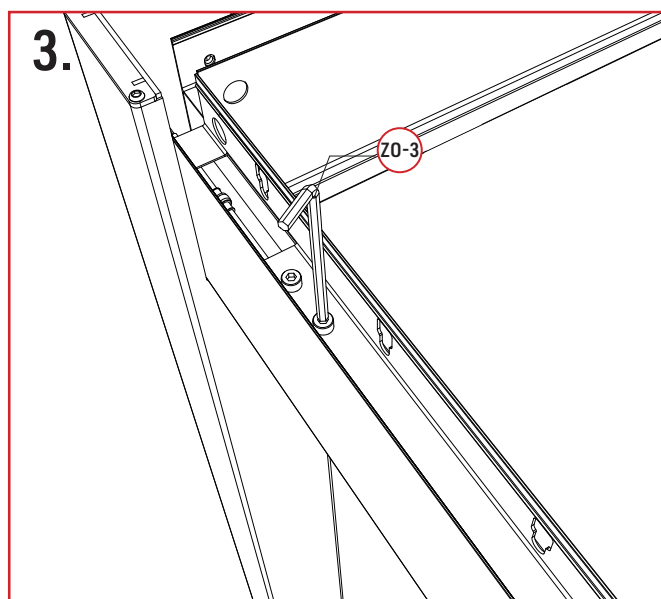
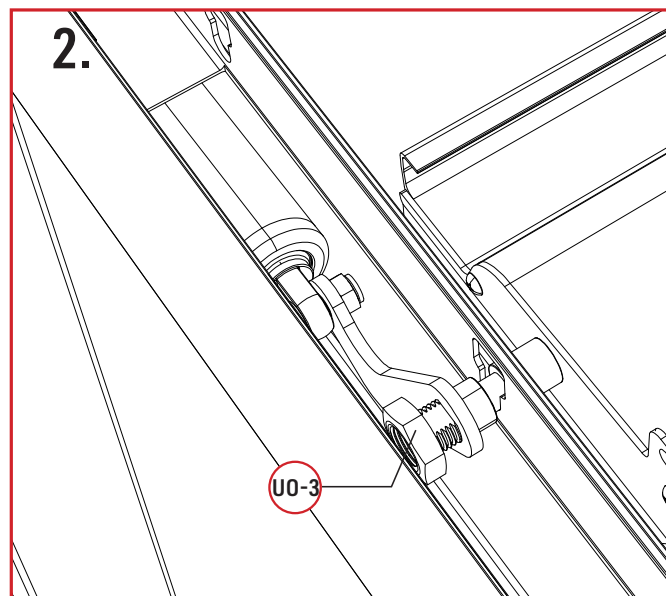
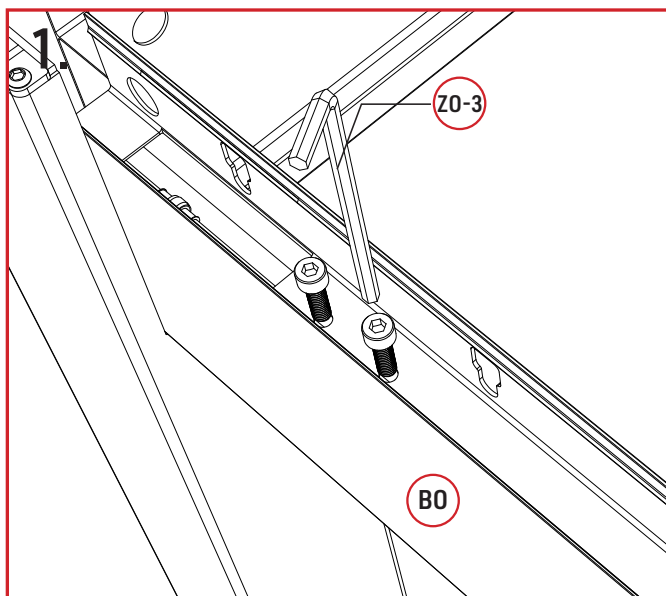

Schritt 4

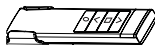
E-R		1
-----	---	---

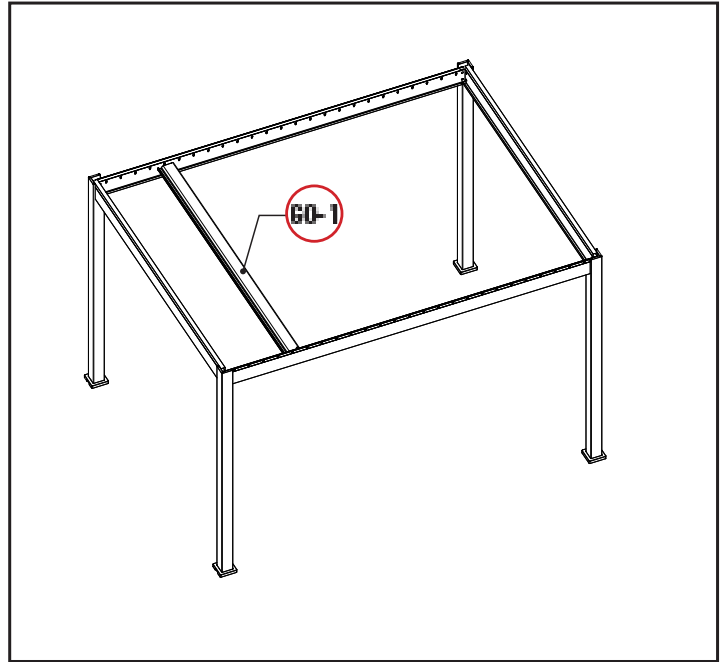

Schritt 1: Nehmen Sie die Fernbedienung zur Hand.

Schritt 2 & 3: Drücken und halten Sie den oberen „Up“-Knopf der Fernbedienung für 5 Sekunden, bis Sie das akustische Signal hören, das die Kopplung zwischen der Fernbedienung und dem Motor anzeigt.

Schritt 4: Nach etwa 5 Sekunden hören Sie ein akustisches Signal, das die Kopplung zwischen der Fernbedienung und dem Motor anzeigt, und Sie können den „Up“-Knopf loslassen.

Schritt 1

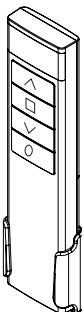

Schritt 2

Drücken und halten Sie für 5 Sekunden

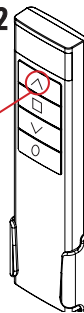

Schritt 3



STROM



AC



Schritt 4

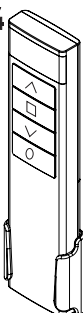

DING

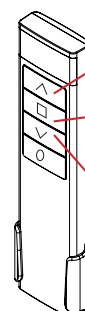
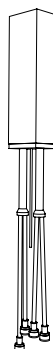

Up

Pause

Down

Verwenden Sie die Fernbedienung, um die Hauptlamelle in eine vertikale Position von 90° zu bringen.

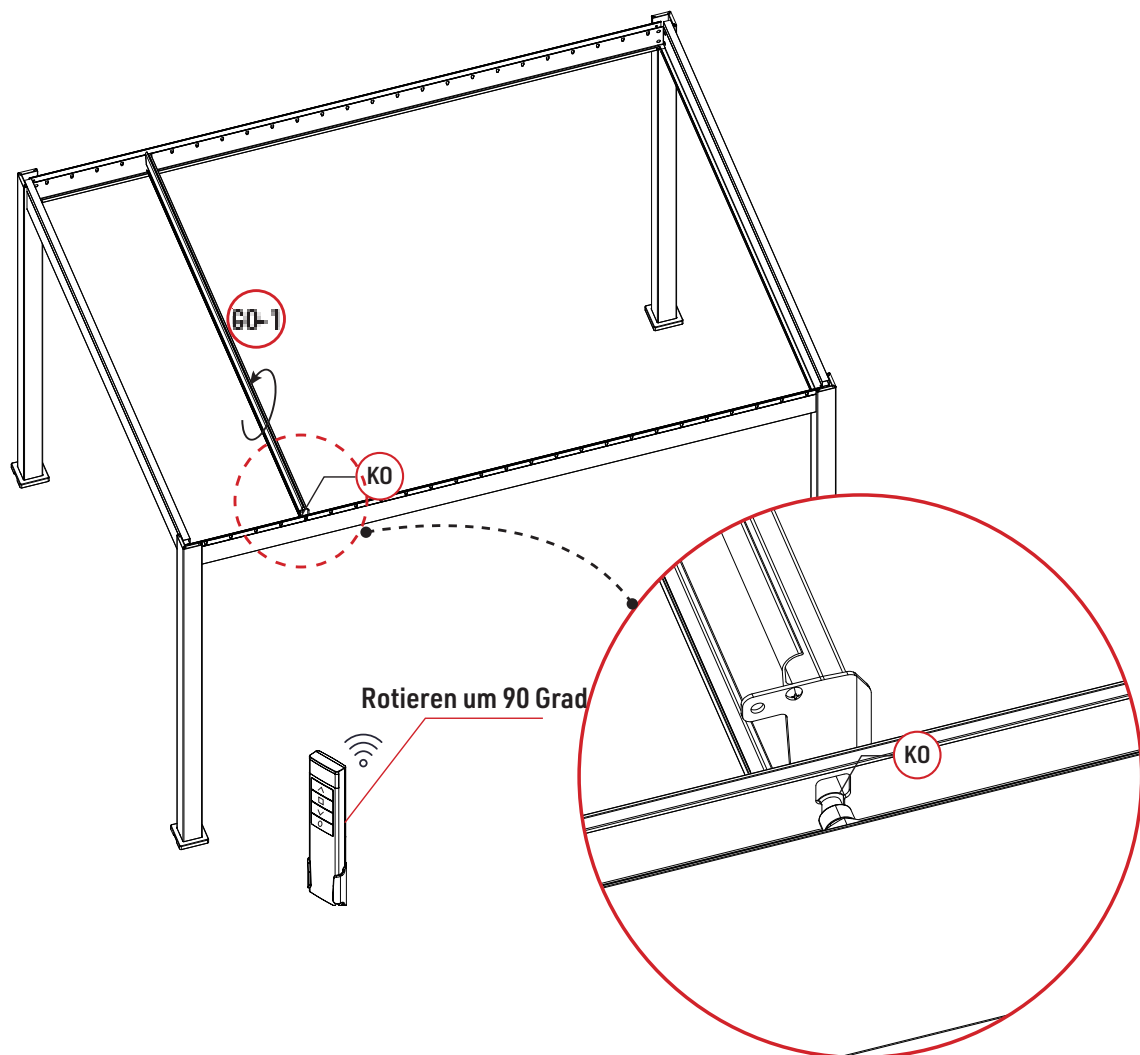

Schritt 4

SO		50
----	---	----

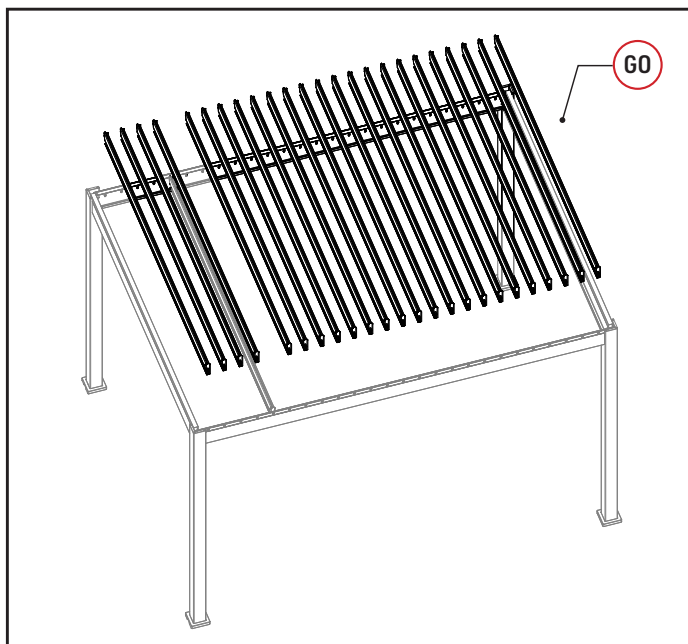

Installieren Sie die 24 Lamellen auf den Balken **BO** und **BO-1**.
Fügen Sie die Halbmondkeile **SO** gemäß der Abbildung ein. Die halbmondförmige Öffnung sollte sich an der unteren Seite der Keile befinden.

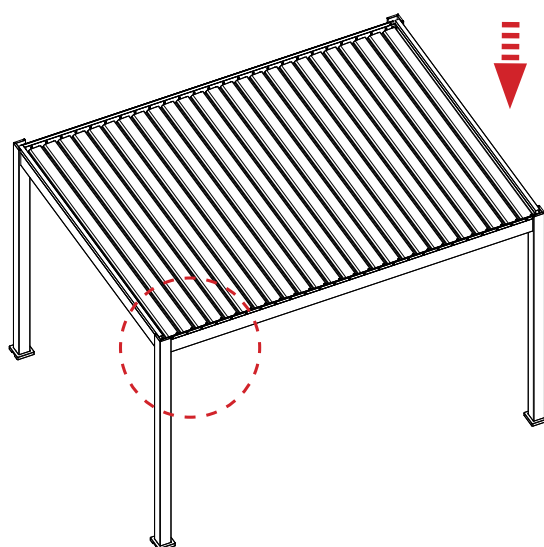

1

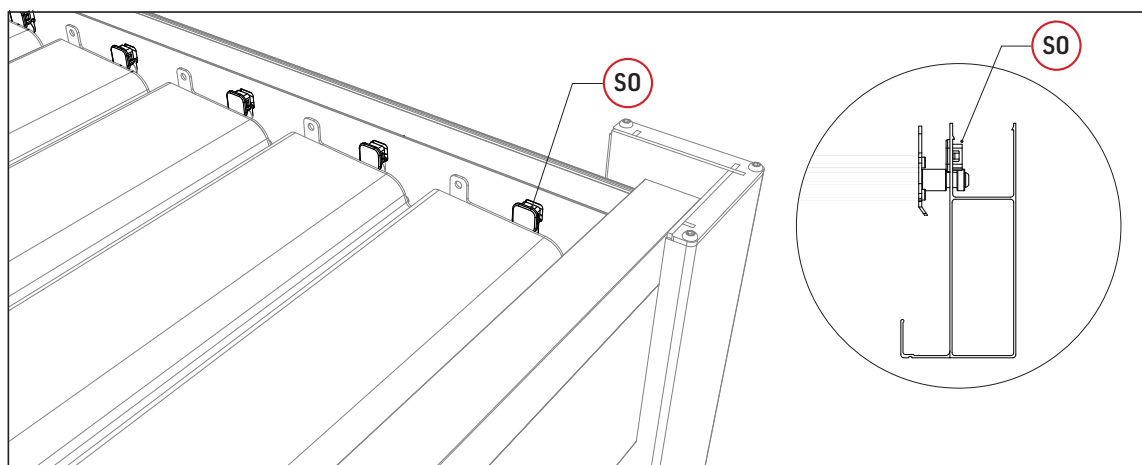

2



Schritt 4

F0		1
V0		25
U0	 lock nut	25



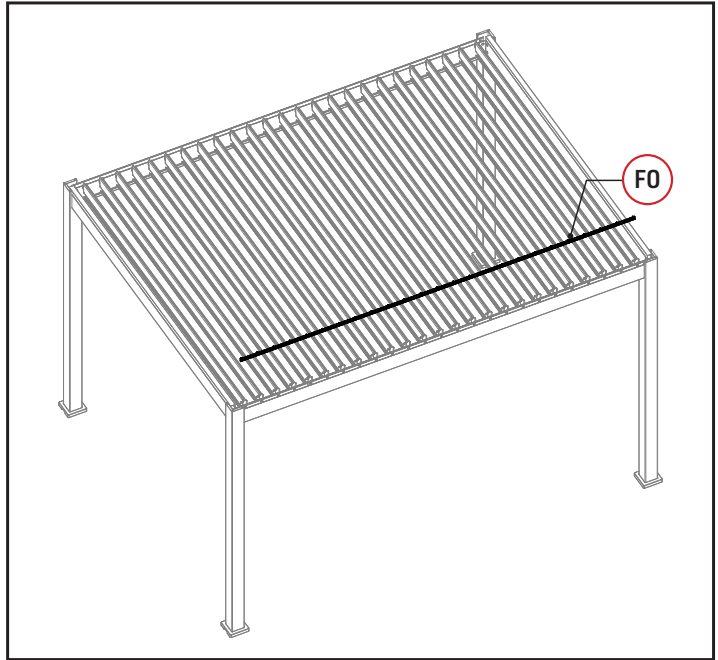

Z0-1	 4mm	1
Z0-2	 4mm	1
Z0-5	 10mm	1

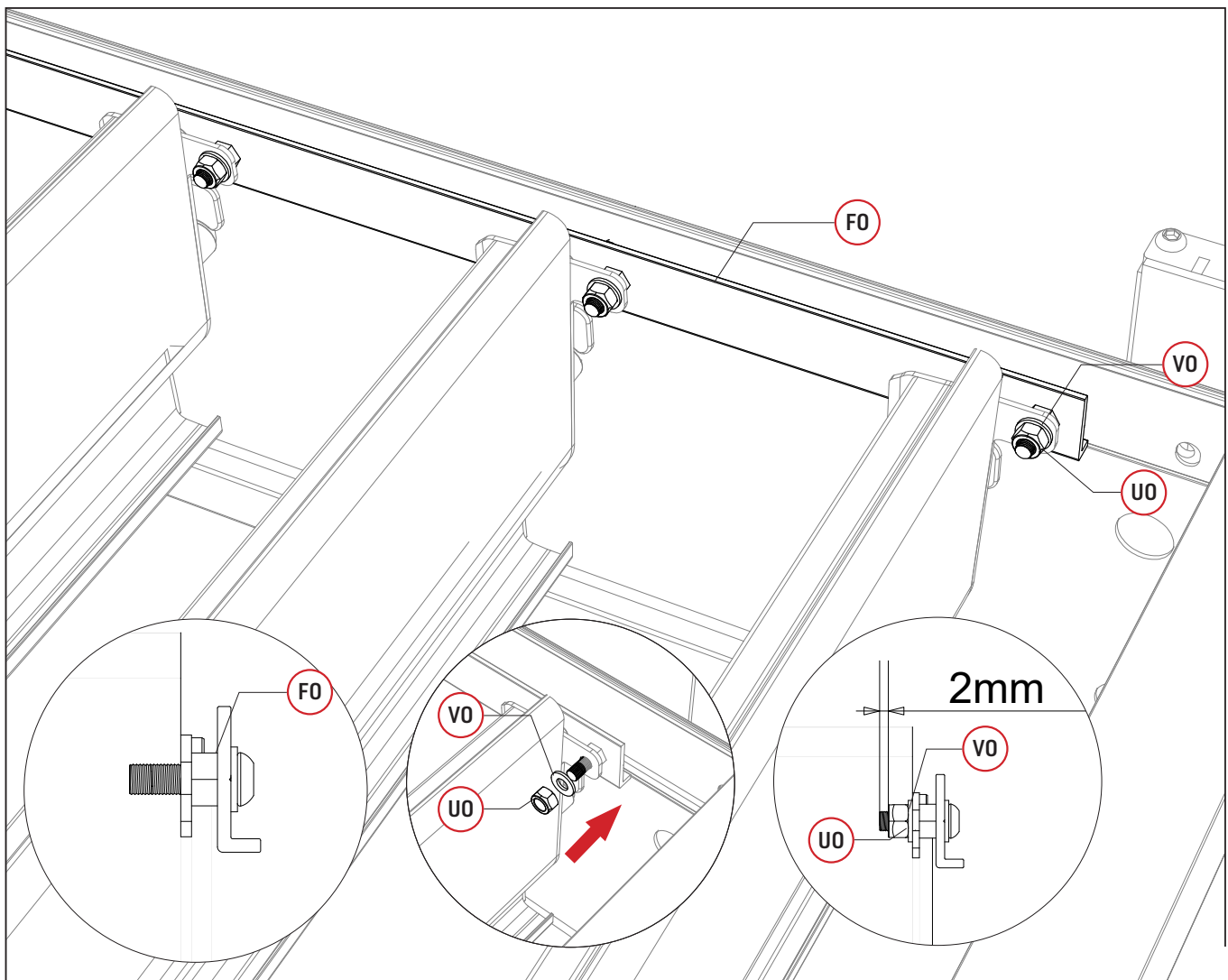

Befestigen Sie die Verbindungsstange **F0** an allen Lamellen. Setzen Sie bei jedem Bolzen auf der Verbindungsstange eine Unterlegscheibe **V0** und eine Mutter **U0** ein. Verwenden Sie zum Abschluss des Vorgangs einen Schraubendreher mit dem Aufsatz **Z0-2** und den Schlüssel **Z0-5**, um die Mutter festzuhalten und anzuziehen. Wiederholen Sie den Vorgang für alle Lamellen, wie auf dem Schema angezeigt.



Schritt 4

DO			2
RO			16
TO			16

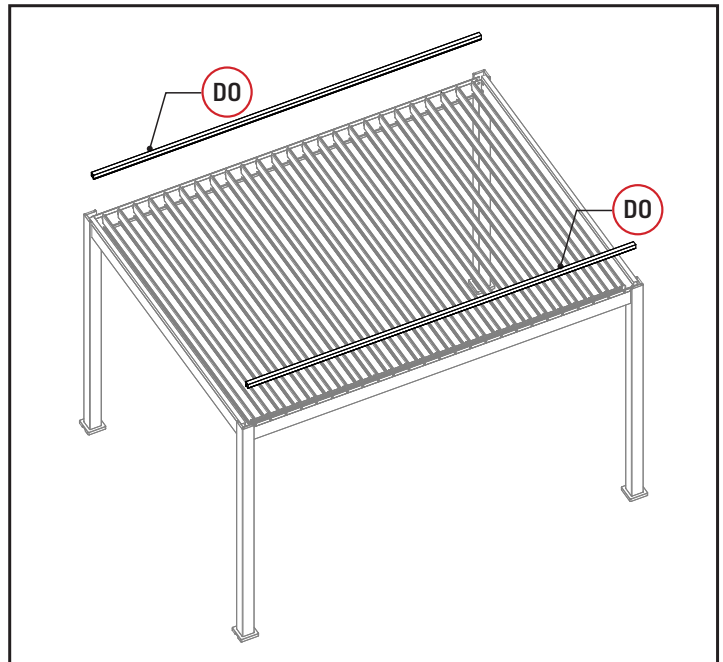

Setzen Sie die Abschlusskappen **RO** ein, um die Löcher in den Ecken des Rahmens zu verdecken, wie auf dem Schema angezeigt.

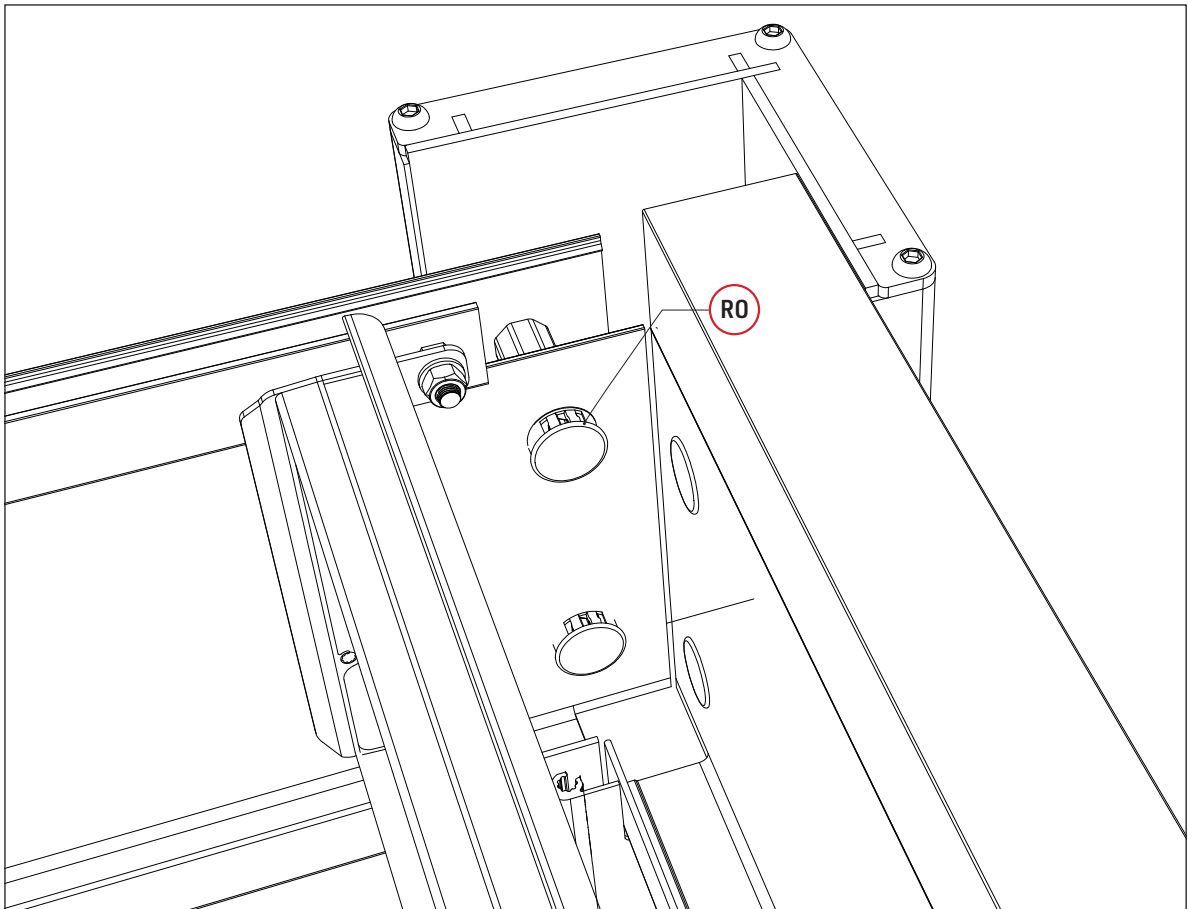

Führen Sie einen Motor-Test mit der Fernbedienung durch, um sicherzustellen, dass die Neigung der Lamellen richtig funktioniert, und installieren Sie dann die Erweiterungen **DO** gemäß der Abbildung auf den Balken.

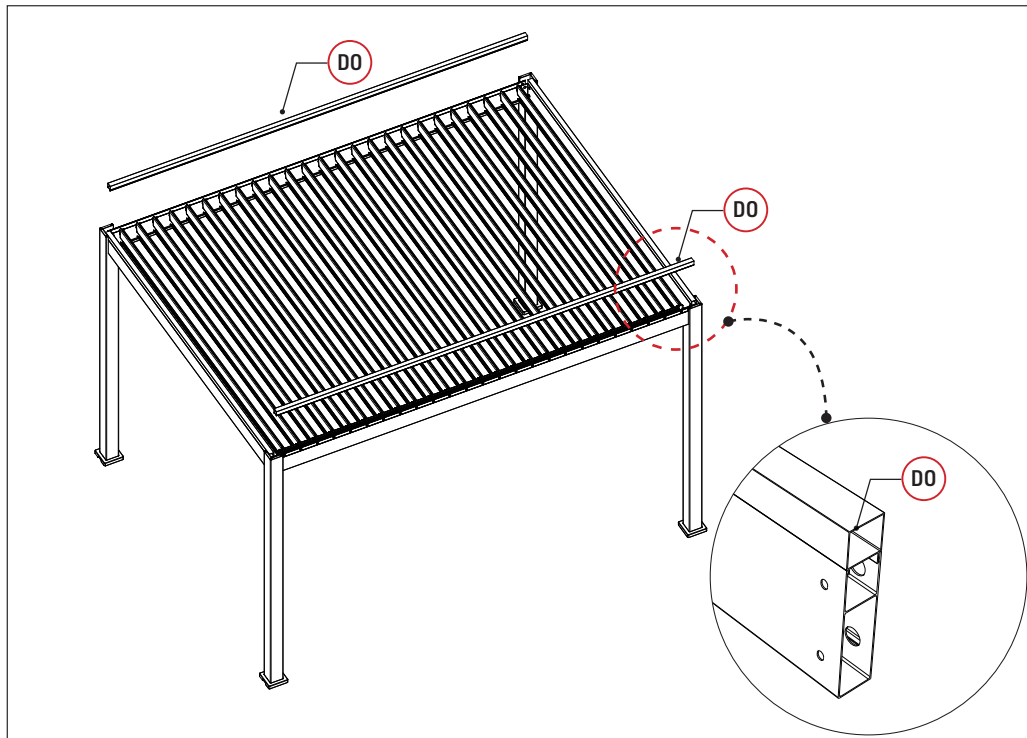

Schließen Sie ab, indem Sie die Pergola auf einem harten, ebenen Betonboden mit Dübeln mit Spreizfunktion **TO** befestigen, unter Verwendung eines Bohrhammers und eines 12-mm-Bohrers (nicht im Lieferumfang enthalten).

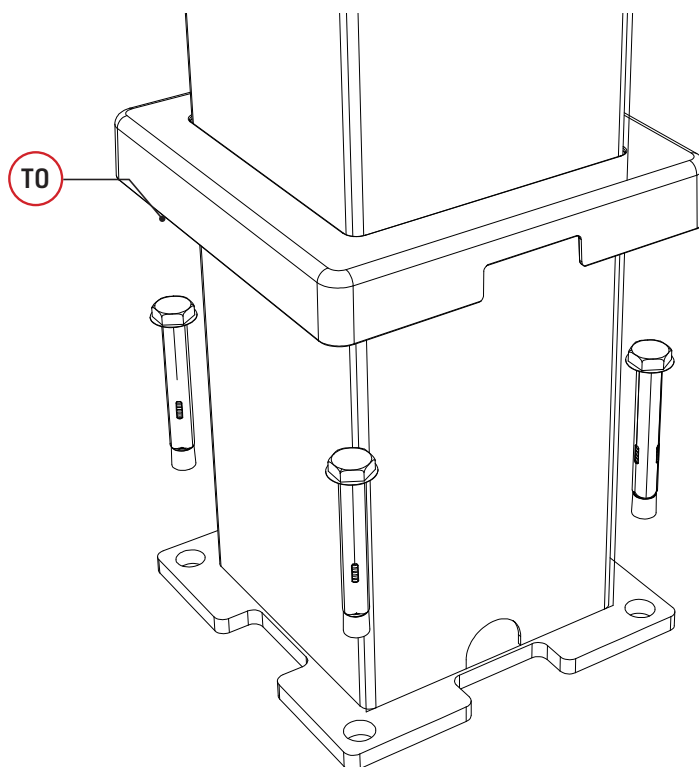

12MM



M17

3x4M freestanding louvered pergola

These instructions have to be saved during the whole product life cycle.

We advise you to read these very carefully before proceeding to the assembly.

The user will be reliable for any damages or injuries caused due to incorrect or improper installation.

1. PRECAUTION OF USE

This product should not be used in extreme weather: storms, violent winds, hail, and snow. We guarantee the resistance of the pergola for winds up to 100 km/h and a maximum snow weight of 50kg/m².

As in the case of strong winds or snow, we highly recommend leaving the louvers open. In the case of omission or neglect the pergola will have to be cleared of any snow to avoid any overload on the louvers.

Our pergola can withstand heavy rain, but we cannot guarantee it will be 100% waterproof.

Exceptional climatic events may compromise the perfect sealing of the product. We advise you not to leave products that are sensitive to humidity under the pergola. We do not recommend climbing on the roof or the structure of the pergola, risking damage and may cause injuries.

2. TIPS AND SAFETY INSTRUCTIONS

Depending on the location and surface area, construction may be subject to building permits. Make sure you have checked with your local authorities to obtain the needed information before the assembly.

Product assembly :

- At least 2/3 people required
- Remove protective film (around 1 hour needed)
- Do not keep children near the assembly area
- Beware of the risk of pinching
- Do not tighten the screws before assembling the whole product
- All assembly steps must be carefully followed.
- Check the level of the structure on all sides
- Do not anchor the pergola before assembling the whole product

No changes can be made to the product. Products tampered with by the user are not covered by the warranty, thus being declared as void.

The location should be chosen carefully. It is recommended to avoid mounting your pergola on a rainy day, facing the prevailing winds, and under an overhanging tree.

The pergola must be mounted on a flat-level foundation. It is recommended to install it on a concrete slab or 25x25 cm concrete pads at each post. Please, anchor the pergola properly to the ground using TO parts.

If you would like to mount your pergola near your house or a building, please check the presence of gutters for water drainage.

We cannot guarantee that Ombréa® pergola can ensure perfect sealing if rainwater from your gutter lines spills on it.

Should these instructions not be followed or only partially, the warranty will be voided by the seller.

3. MAINTENANCE

- Regular maintenance is necessary to ensure its longevity and aesthetic appearance. We recommend to :
 -
 - • Clean your pergola once or twice a year with fresh water using a sponge or cloth.
 - • Do not use detergent or an abrasive material.
 - • Check the tightness of the screws regularly (at least once a year).
 - • Oil fastening regularly (at least once a year).
 - • Make sure that nothing hinders the water flow in the gutters (leaves, branches...).
 - • Remove any water that might stagnate around the legs of the pergola (lift the posts skirts).

4. WARRANTY

Ombrea® guarantees the availability of the spare parts for 2 or 5 years (depending on the product). It only applies if the storage, assembly, use and maintenance instructions are respected.

This warranty does not cover :

- Normal wear and tear inherent from the products.
- Loss or breakage of any part during unpacking or installation.
- Lack of care, neglect, vandalism, impact with foreign body, force, contact with abrasives material, product aesthetics, disassembly, rebuilding or relocation.
- Force majeure: hail, high winds, storms, snow, floods, lightning etc...
- Product tampered with by the user.

The warranty only takes in account the replacement of spare parts or the provided product, no refund will be issued.

All warranty claims must be made at the sales outlet (store or website) where the product has been purchased.

5. PARTS LISTS (PER CARTON)









Before proceeding with the assembly of your louvered pergola, it is necessary to check that all parts listed are supplied and not damaged.



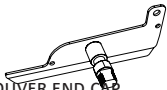

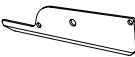

Any missing part must be reported within 10 days of delivery.

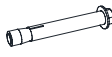

Do not discard the packaging without ensuring that the product is functioning properly.

CARTON 1/4 (POSTS AND LOOSE PARTS)

Reference	Parts	Quantity
A0	 POST	4

Reference	Parts	Quantity
I0	 POST SKIRT	4
J0	 POST BASE PLATE	4
K0	 MAIN LOUVER END CAP	1
L0	 A LOUVER END CAP	24
L0-1	 B LOUVER END CAP	25
M0	 SPRING PIN	49
Q0	 BEAM FIXING SCREW 6mm	16
R0	 CIRCLE CAP	16

Reference	Parts	Quantity
S0	 HALF MOON PLASTIC CAP	50
T0	 CONCRETE EXPANSION	16
U0	 NUT	74
U0-3	 NUT	1
W0	 SCREW 4X16 PH2	100
X0	 BOLT 6X40 4mm	49
X0-1	 BOLT 6X35 4mm	16
V0	 WASHER	25



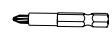

Reference	Parts	Quantity
Z0-1	 4MM ALLEN KEY	1
Z0-2	 4MM HEX BIT	1

Reference	Parts	Quantity
Z0-5	 10MM FLAT WRENCH	1
Z0-6	 PH2 TORX BIT	1



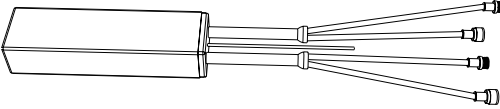

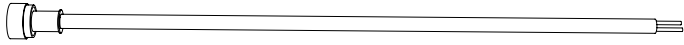
Z0-3		1
------	---	---

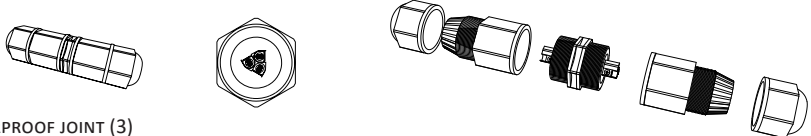
Z0-4		1
------	---	---

MOTORISATIONS PARTS

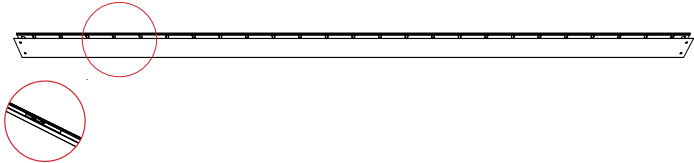
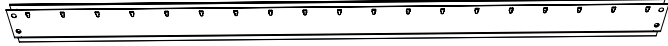
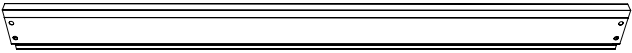
Reference	Parts	Quantity
E-C	 CONTROLLER	1
E-R	 REMOTE CONTROL	1
E-P	 POWER CABLE (M15) =4000mm	1
E-W2	 WATERPROOF JOINT (2)	1
E-W3	 WATERPROOF JOINT (3)	1

CARTON 2/4 (POUTRES)

Reference	Parts	Quantity
B0	 MAIN BEAM	1
B0-1	 BACK BEAM	1
C0	 SIDE BEAM	1
C0-1	 SIDE BEAM	1
DO	 BEAM EXTENSION	2
F0	 CONNECTING	1
HO	 L-shaped beam	1

CARTON 3/4 BEAMS

Reference	Parts	Quantity
E-T		1

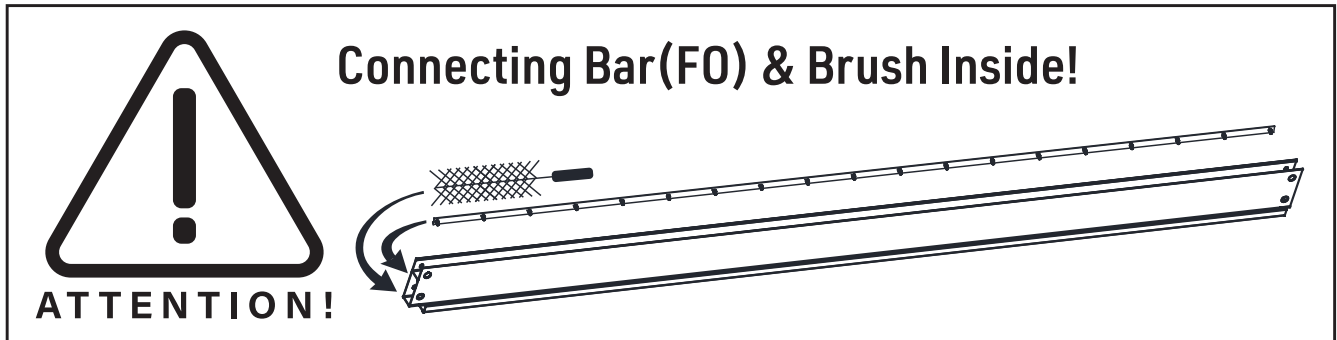

CARTON 3/4 (LOUVERS AND LOOSE PARTS)

Reference	Parts	Quantity
GO		13

CARTON /4 (LOUVERS)

Reference	Parts	Quantity
GO		12

The parts from aluminium are AO, BO, BO-1, CO,CO-1, DO, FO, GO, IO, KO, LO et LO-1.

Screws, bolts, and other loose parts are either from stainless steel, galvanized steel, nylon, or plastic.

6. NECESSARY TOOLS AND SAFETY GEAR (NOT SUPPLIED)



Safety glasses and
Work gloves



2 Ladders



Electric drill +
12mm concrete



Electric screwdriver

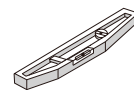

Spirit level

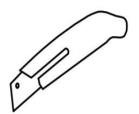

Cutter



Safety Helmet

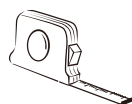

Tape measure



M17

7. CONTACT

We would like to thank you for your purchase and wish you happy days under your new brand Ombrea pergola !

8. FOOTING MEASUREMENT (DIMENSIONS IN MM)

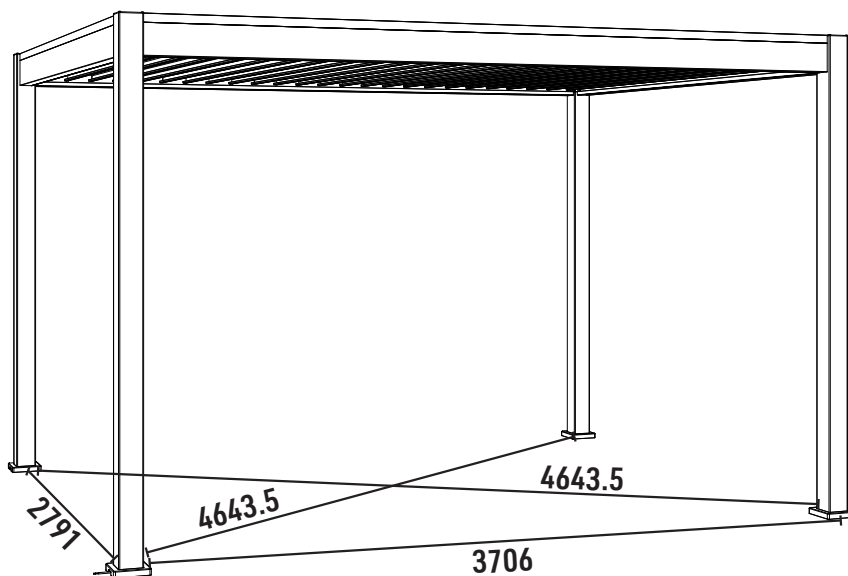
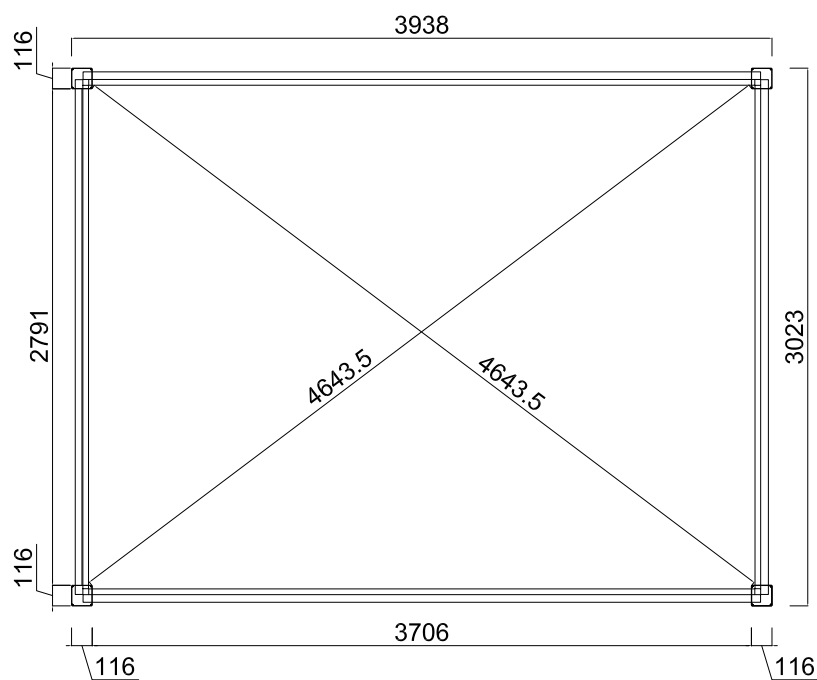

9. ASSEMBLY GUIDELINES

- STEP 1: FRAME AND POSTS
- STEP 2: ELECTRICAL INSTALLATION
- STEP 3: BLADE INSTALLATION
- STEP 4: FINISHING AND FIXING



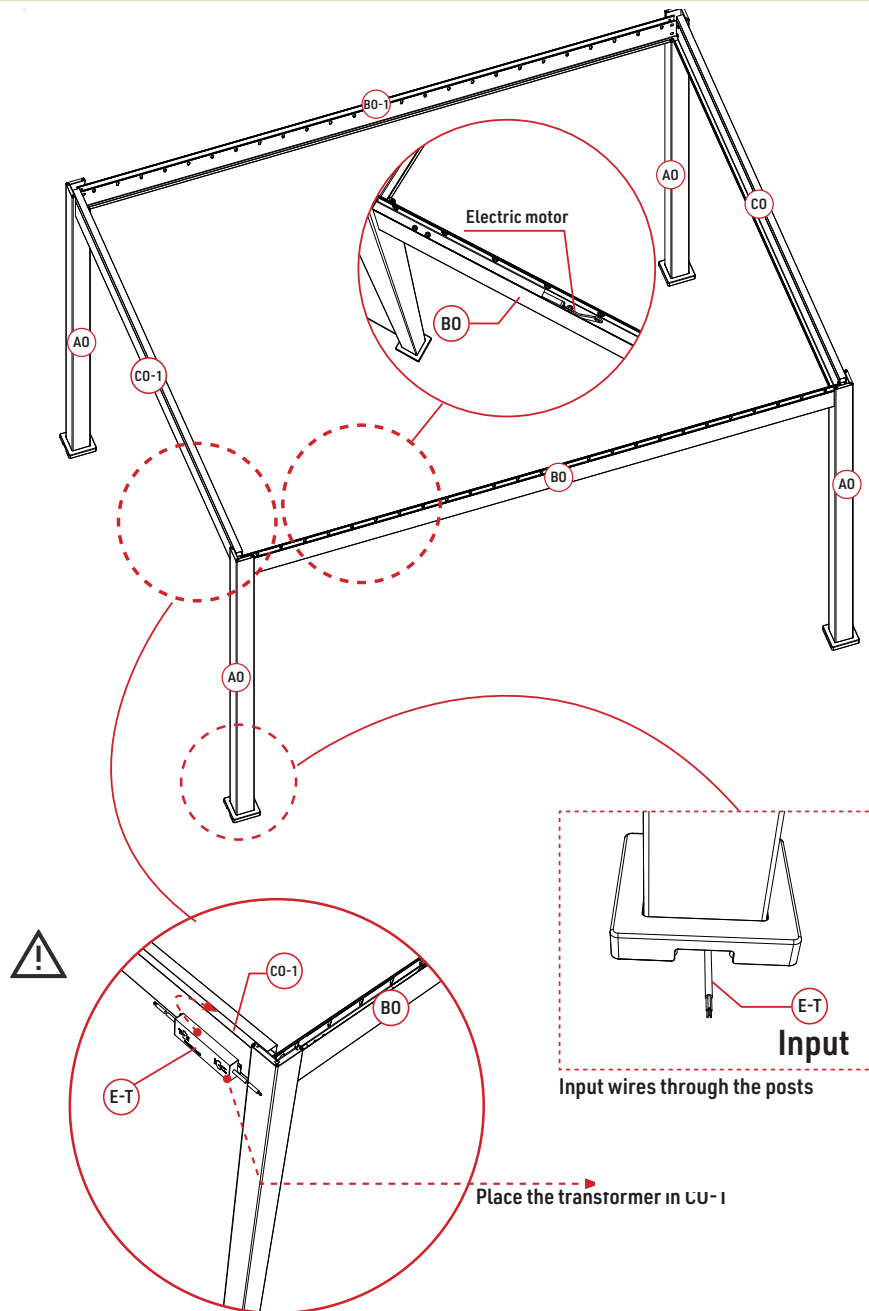

To prevent any damage to your pergola, we recommend to place the parts either on a table, trestles or a smooth and clean surface.



STEP 1



As the pergola is motorised, the motor is located in the front beam **BO**. The power cable passes through the **AO** post located to the left of beam **BO**.

STEP 1

A0		4
IO		4
J0		4
X0-1	 4x35 4mm	16

Z0-1	 4mm	1
Z0-2	 4mm	1

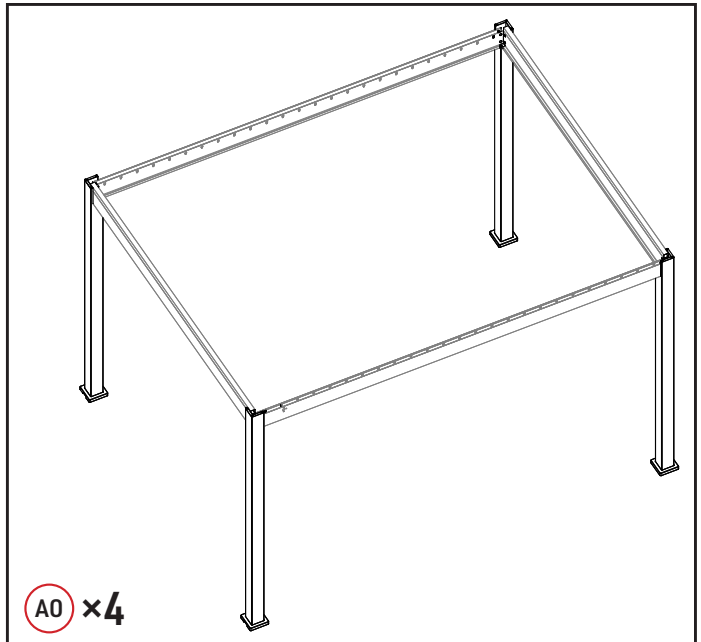

Slide the **IO** covers onto the **A0** posts, positioning the opening in the same direction as the opening on the half-moon post. As shown in the diagram.

Then fix the **J0** plate with the **X0-1** screws using a screwdriver and the **Z0-2** bit. Start by tightening lightly, then fully once all the screws are in place.

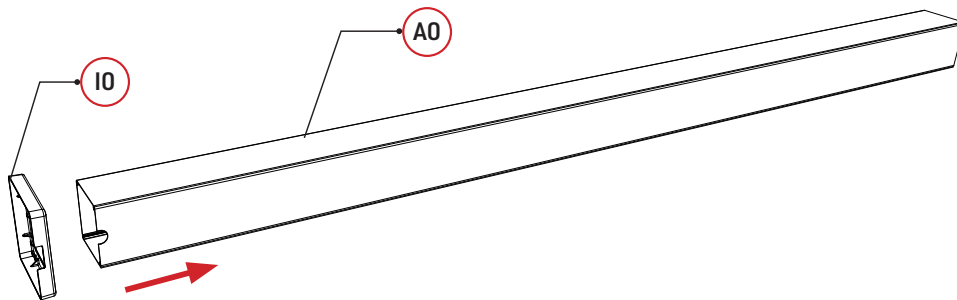

1.

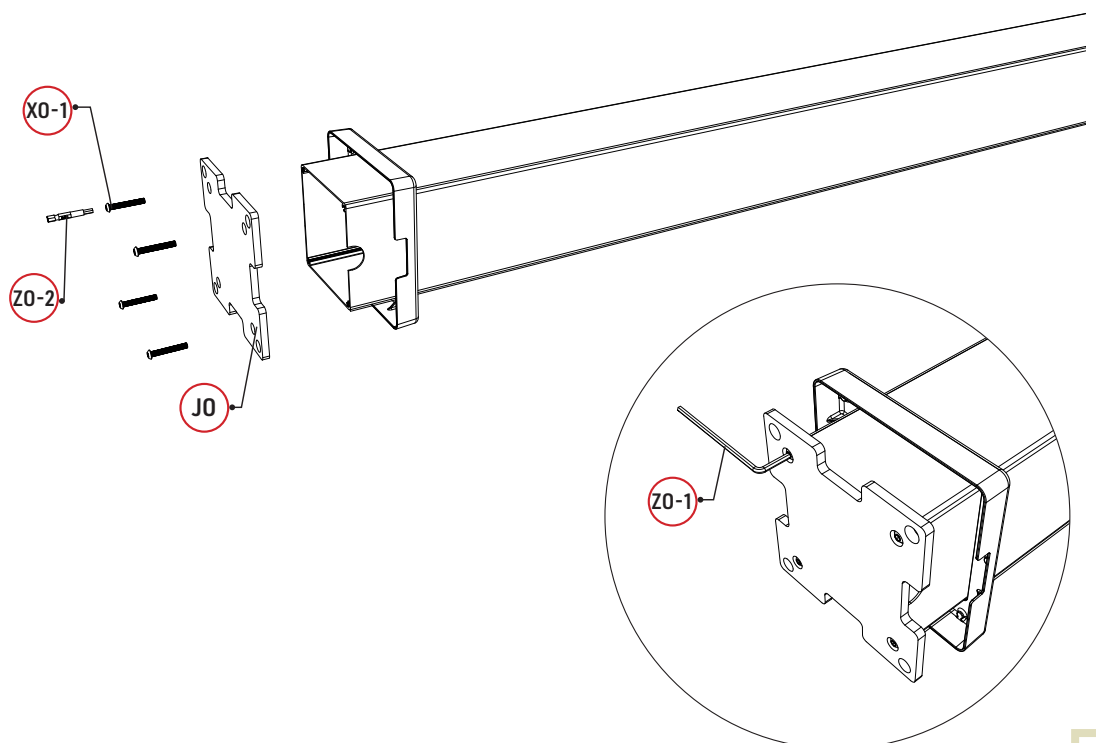

2.

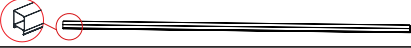

STEP 1

B0		1
B0-1		1
DO		2

Remove **DO** Beam extension from the beams **B0**, and **B0-1**. Keep for later.

1.

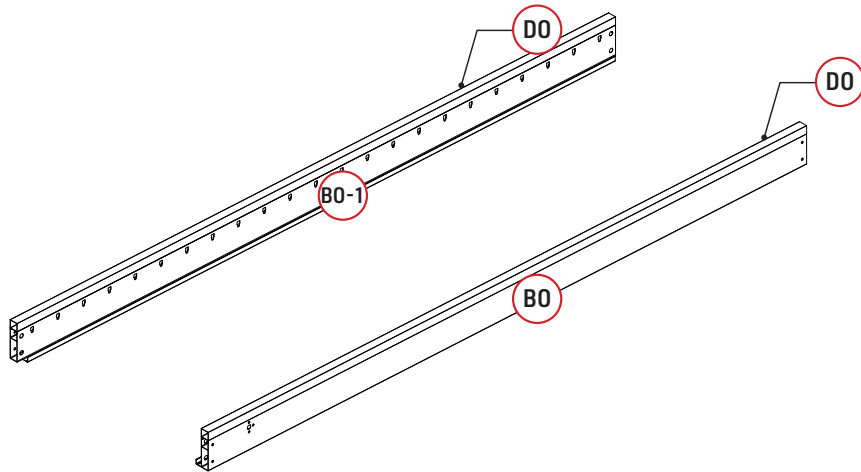

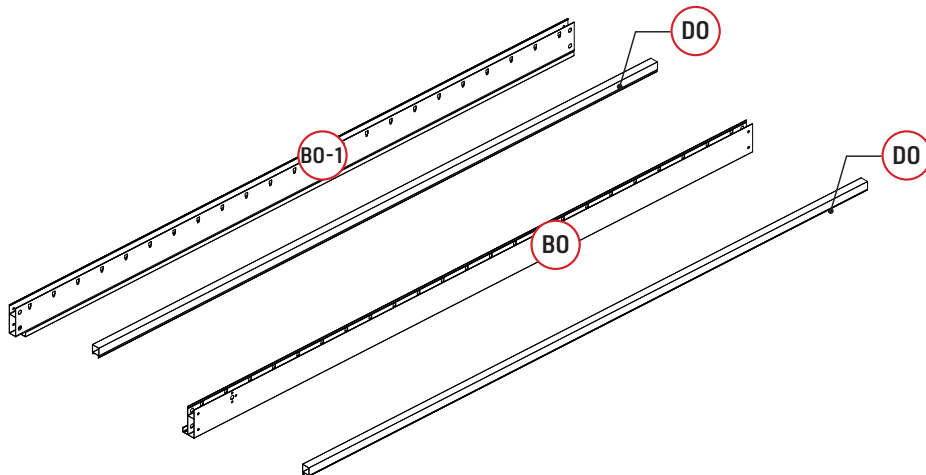

2.





STEP 1

CO		1
CO-1		1

E-T	 Transformer	1
-----	--	---

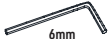
Q0		8
----	---	---

Z0-3		1
Z0-4		1

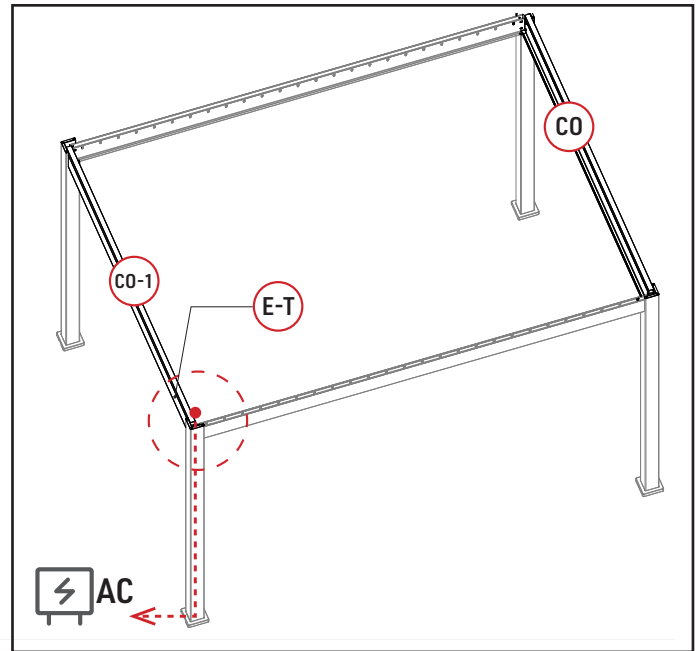

Insert the **E-T** transformer into the **CO-1** beam as shown in the diagram. Make the Output and Input parts of the beam stand out.

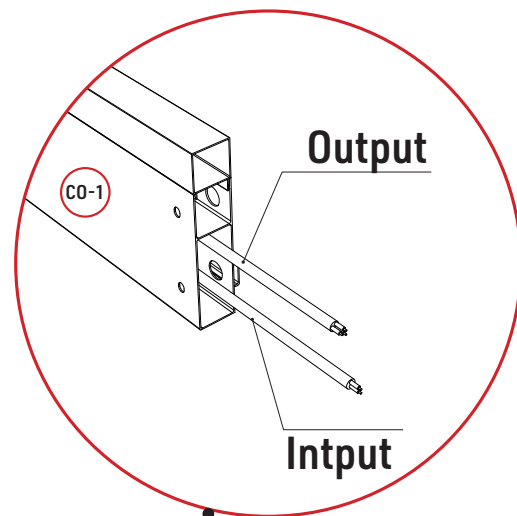
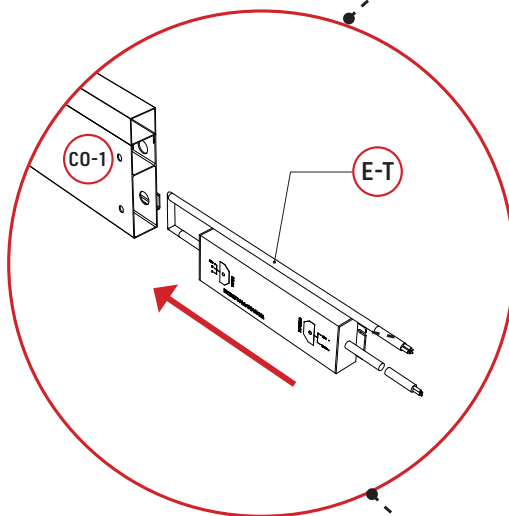
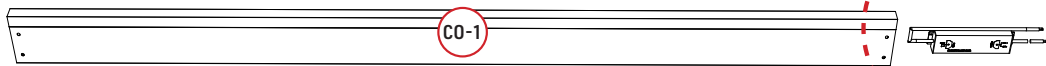

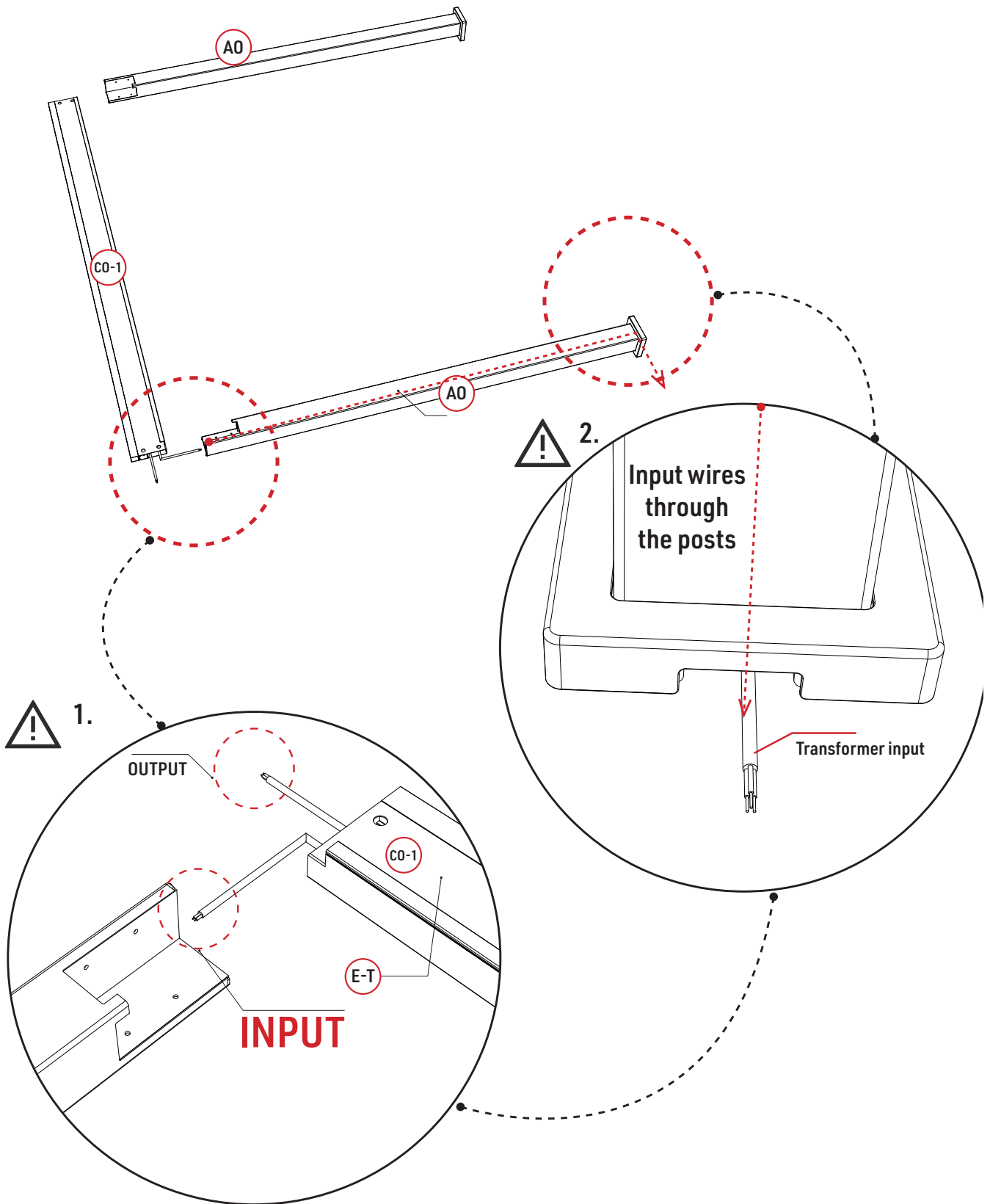

Insert the **CO-1** beam into the **AO** posts, insert the cable **INPUT** from part **E-T** into the **AO** post and lead it out through the water drain.

Fix the **CO-1** beam to the **AO** posts using the **QO** screws on each side, using a screwdriver and the **ZO-4** bit or the **ZO-3** Allen key.

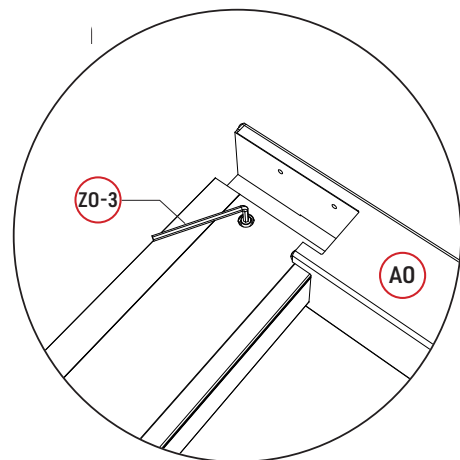
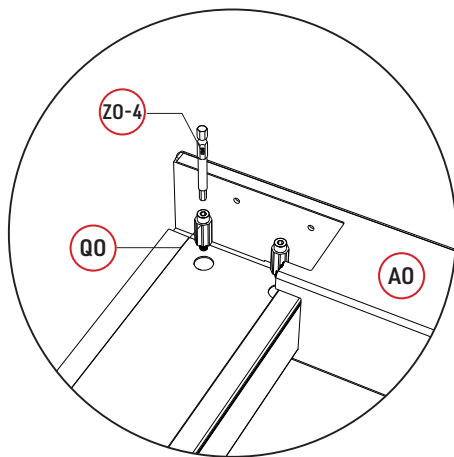
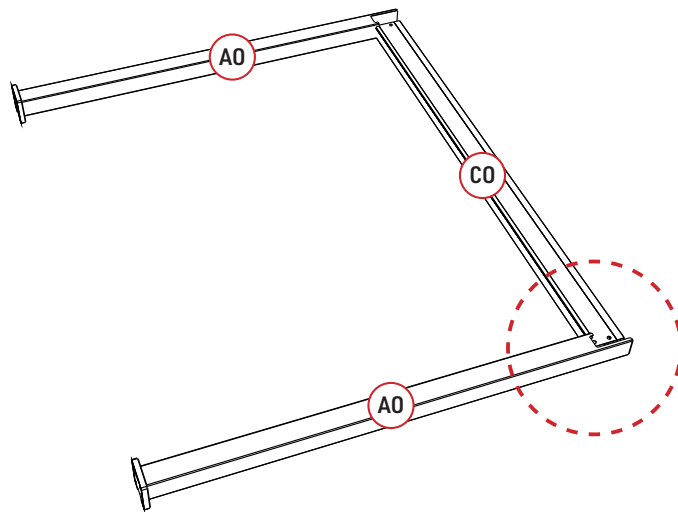
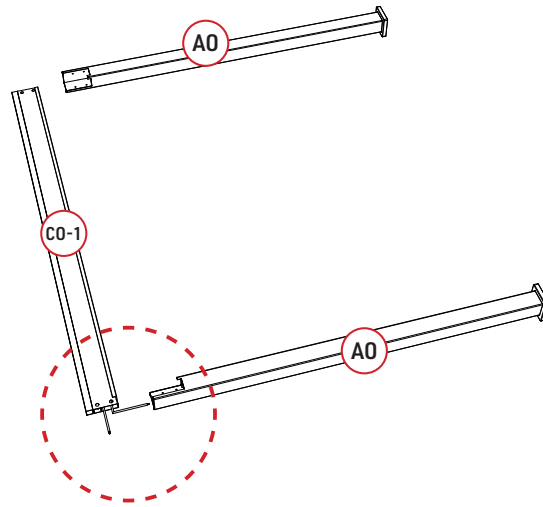

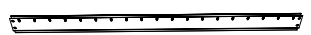

Repeat the operation to fix the **CO** beam to the **AO** posts.

STEP 1

B0		1
BO-1		1

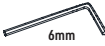
Q0		6mm	8
----	---	-----	---

Z0-3		6mm	1
Z0-4		6mm	1

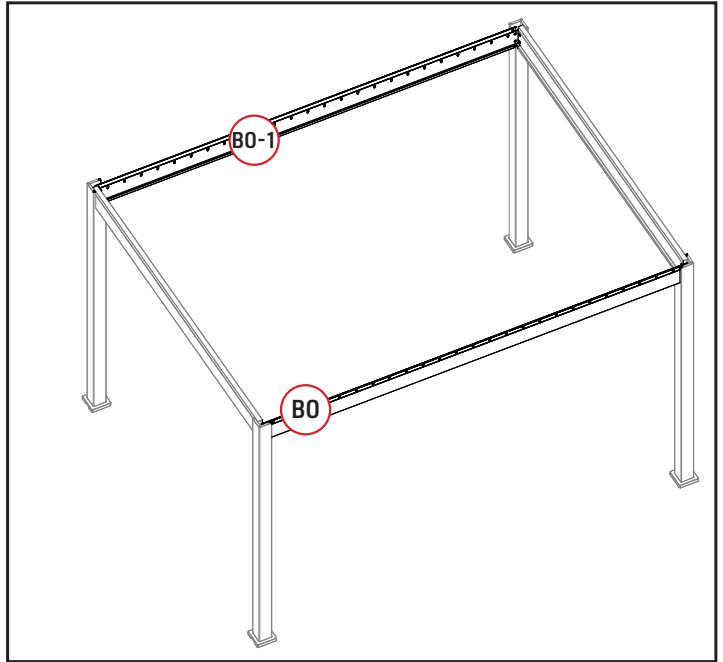

With the help of 2/3 people (one to maintain the structure, one to install it and one to assist with installation), insert the **B0** and **BO-1** beams on the **AO** posts as shown in the diagram, and secure the beams with the **Q0** screws using a screwdriver and the **Z0-4** bit or the **Z0-3** Allen key.

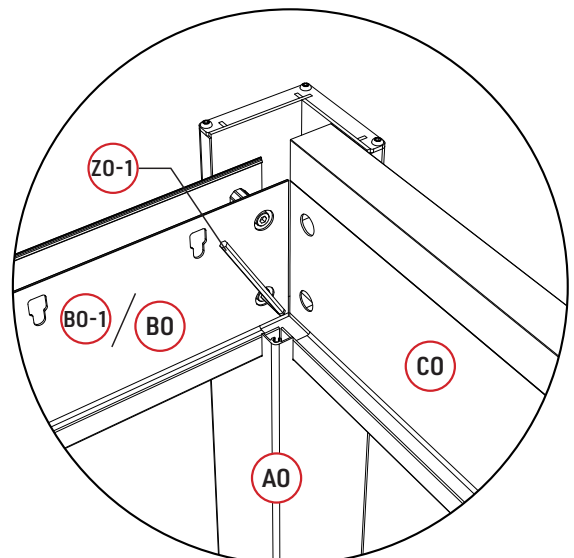
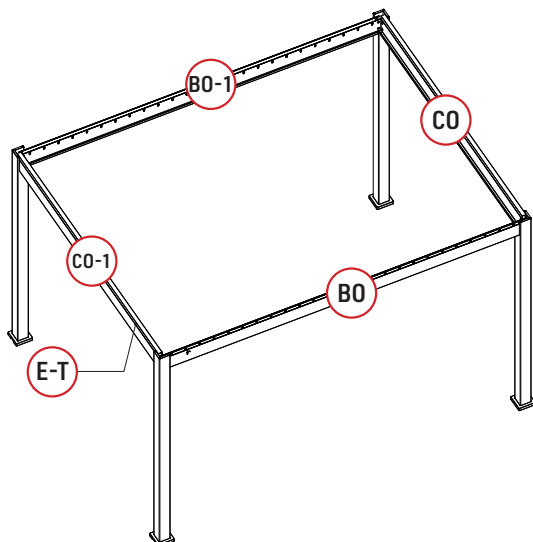
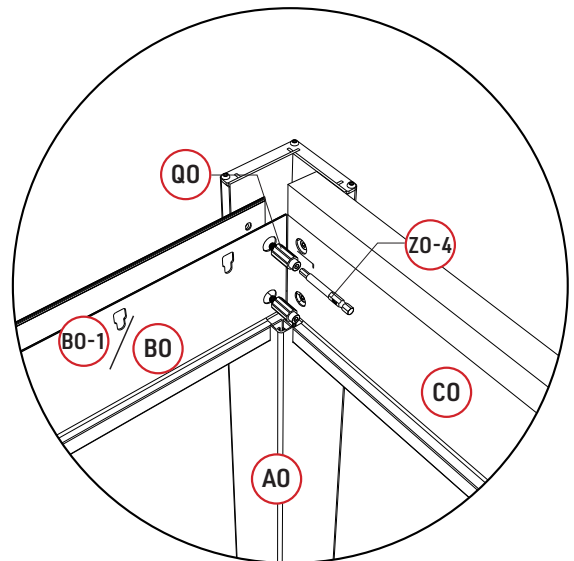
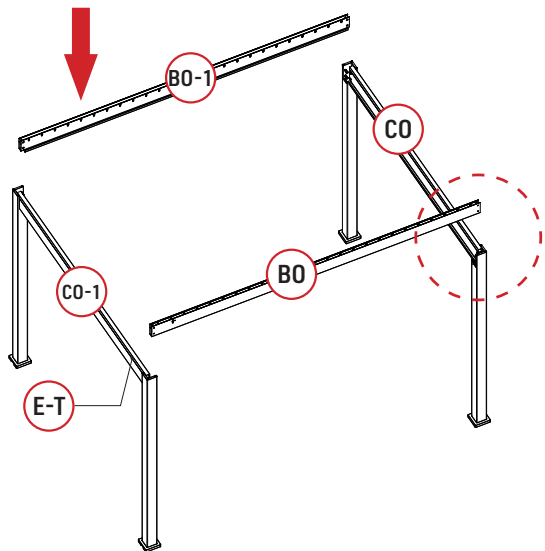

Insert the controller EC into the BO beam.

STEP 2

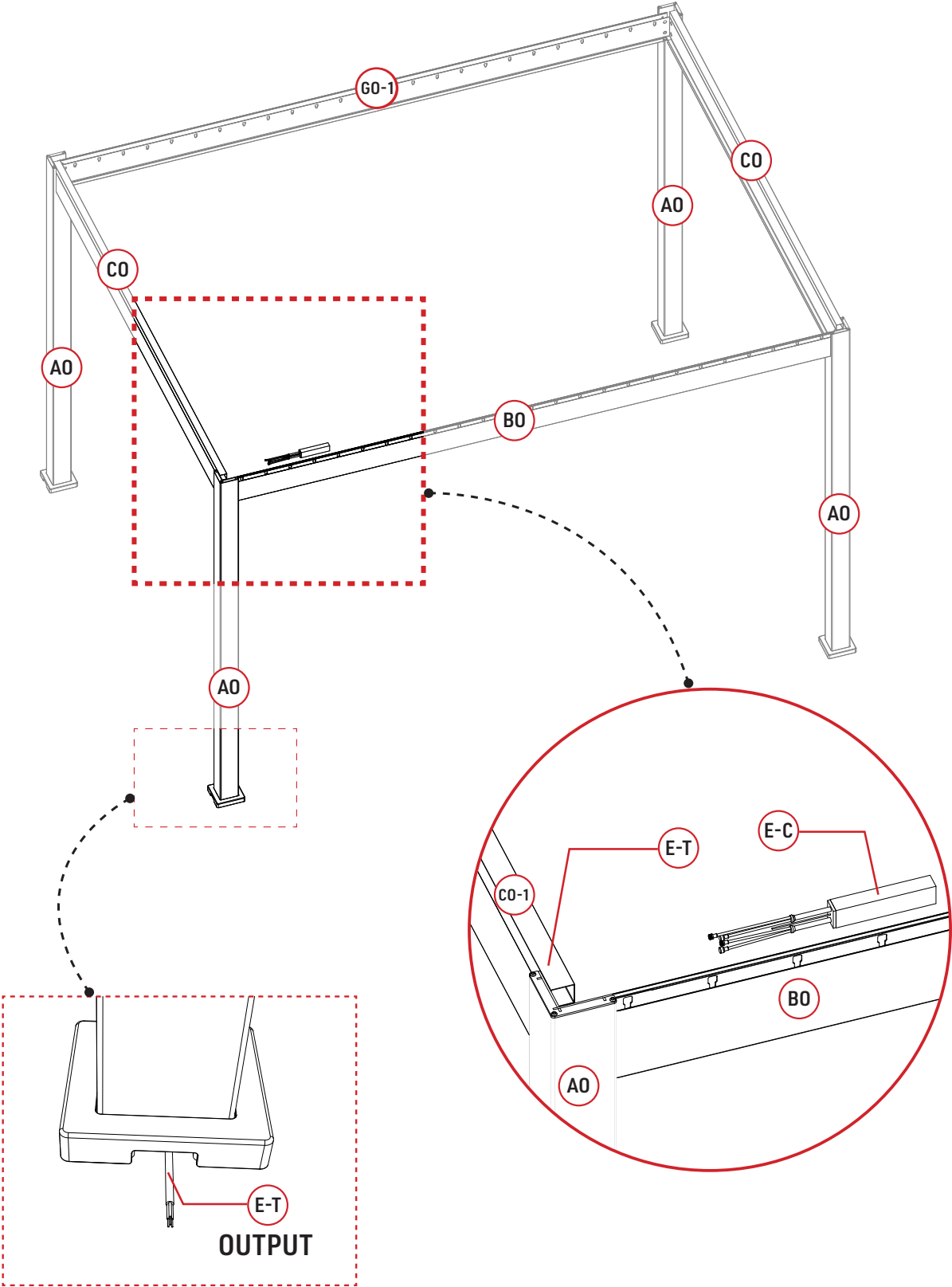

Here are the different electrical components that make up your connection.

STEP 2

Controller

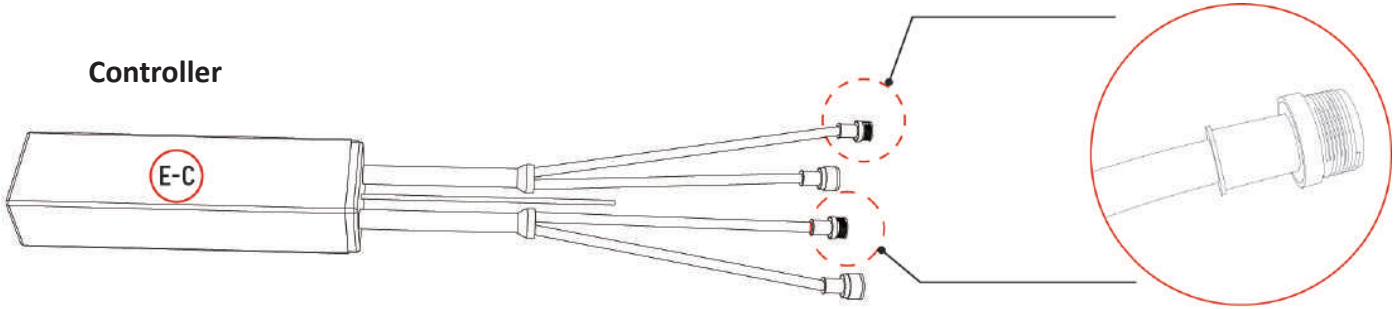

Transformer

<p>INPUT AC L N Y&G</p>	<p>MODEL:H-PF-24V400W</p>	<p>IP67 CE RoHS FC ENEC</p>	<p>OUTPUT Brown + DC24V Blue -</p>
<p>PRODUCT:LED CONVERTER INPUT:100~265V~4.5A 50/60Hz 400W OUTPUT:24V=16.6A(16.6A@50°C) PF:0.95max EF:0.95 ta/tc:-40°C-50°C/75°C</p>		<p>Use within the specified rating. Wired accurately after verifying wiring diagram. Ground the earth terminal to prevent electrocution during the. Installation with the space of 50mm or more in between. Certainly install after reading the installation manual on.</p>	
<p>MADE IN CHINA</p>			

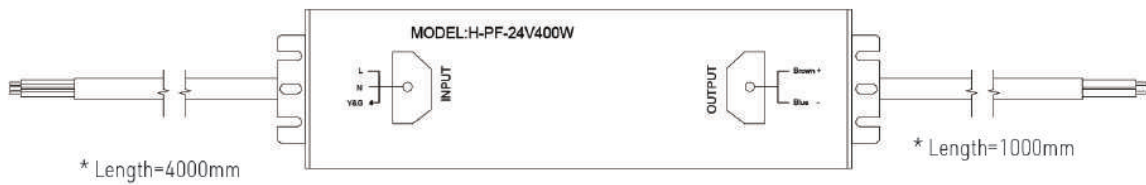

STEP 2

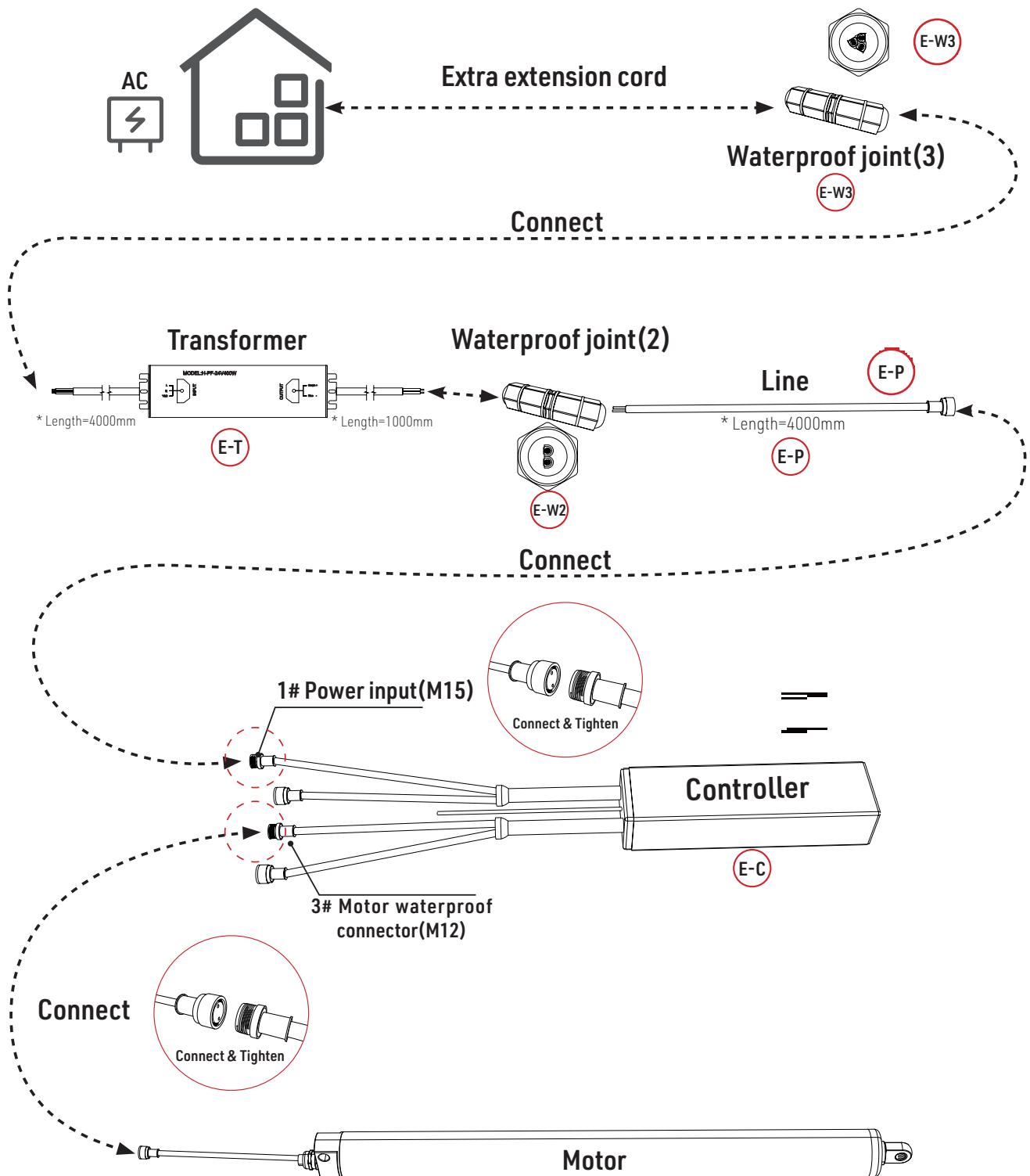

- Make the electrical connections as follows:
 - - Connect the motor in the **BO** beam to the **E-C** controller using the appropriate connection,
 - - The controller must be connected to the **E-P** power cable and then to the **E-W2** waterproof joint (2),
 - - Continue with the connection between the **EW-2** waterproof seal and the **E-T** transformer,
 - - Add the waterproof seal (3) **E-W3** to the **E-T** transformer,
 - - Complete the installation by making the connection to your home.
- Translated with DeepL.com (free version)

Installation du kit LED

STEP 1 :

The LED bars are attached directly to the gutters on the beams, as shown in the diagram.

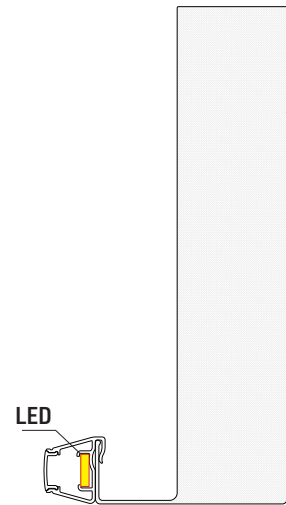

Refer to the instructions for the motorized pergola and make sure the correct position of the transformer and connector.

STEP 2

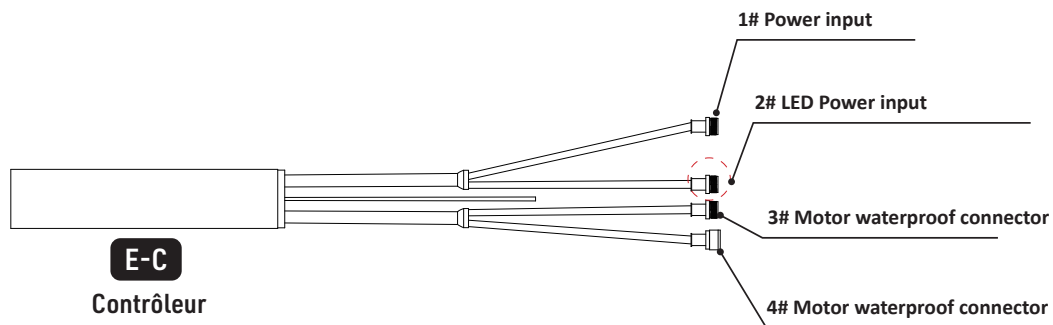

Connect the L-C1 LED controller to the E-C pergola controller on one side and the LC-1 controller to the LED cable on the other, as shown in the diagram.

STEP 3 :

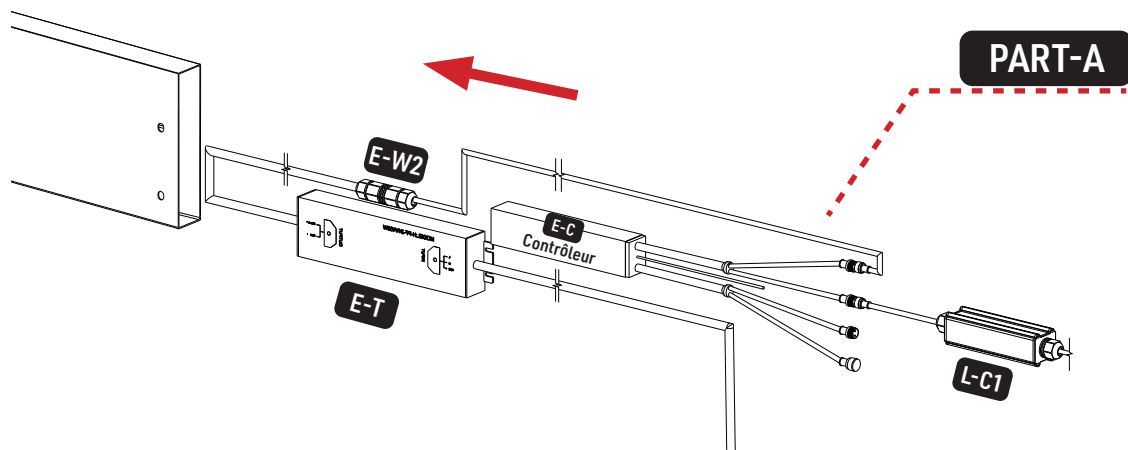

After connecting the LC-1 controller to the E-C controller, place the assembly in the beam cavity,

STEP 4 :

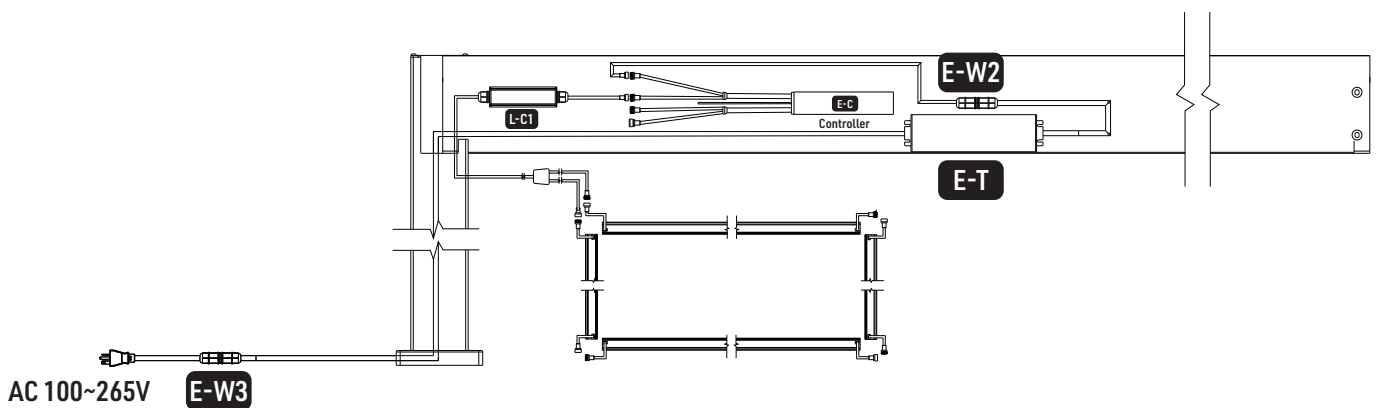

The transformer's 'input' cable passes through the pole and exits through the pole's drain to be connected to the house's power supply.

To be connected to the house power supply and the "output" part of the LED controller must be connected to the LED cable.

APPLICATION LOGIN



Pergola lighting works through an app.

Please download the Tuya Smart or Smart Life app (depending on the country you're in) from the App Store or Google Play.

STEP 1 :

Press and hold the Match/Set button for 2 seconds, or press the Match/Set button twice quickly, then clear the previous network connection and enter Smart config mode. A purple LED will flash rapidly, then blink 10 times.

STEP 2 :

Repeat powering on and off for 5 consecutive times, deleting the previous network connection as well, then enter Smart config mode and the LED will flash 10 times again.

If connection to the Tuya app network is successful, the LED will stop flashing purple and turn red.

TUYA APPLICATION INTERFACE

WHITE LIGHT INTERFACE :

Touch the slider, the white light will appear and then you can adjust the brightness.

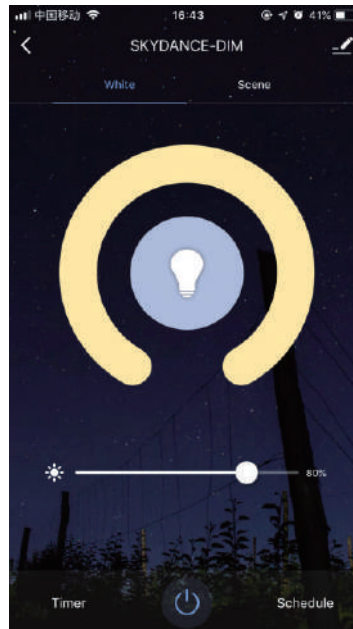

COLOR LIGHT INTERFACE :

Touch the circle to choose the color, then with the first slider you can set the brightness and with the second the color saturation (to make a gradient from the chosen color to white).

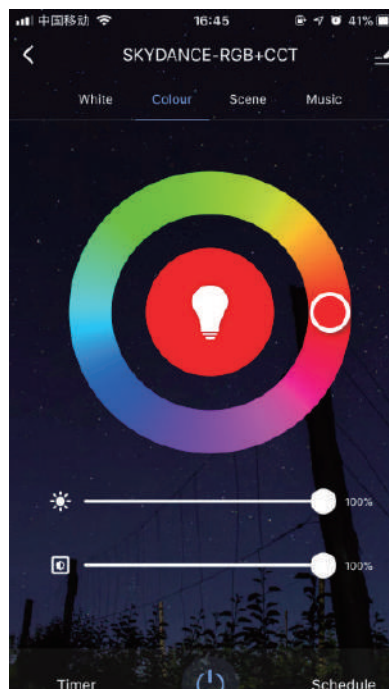



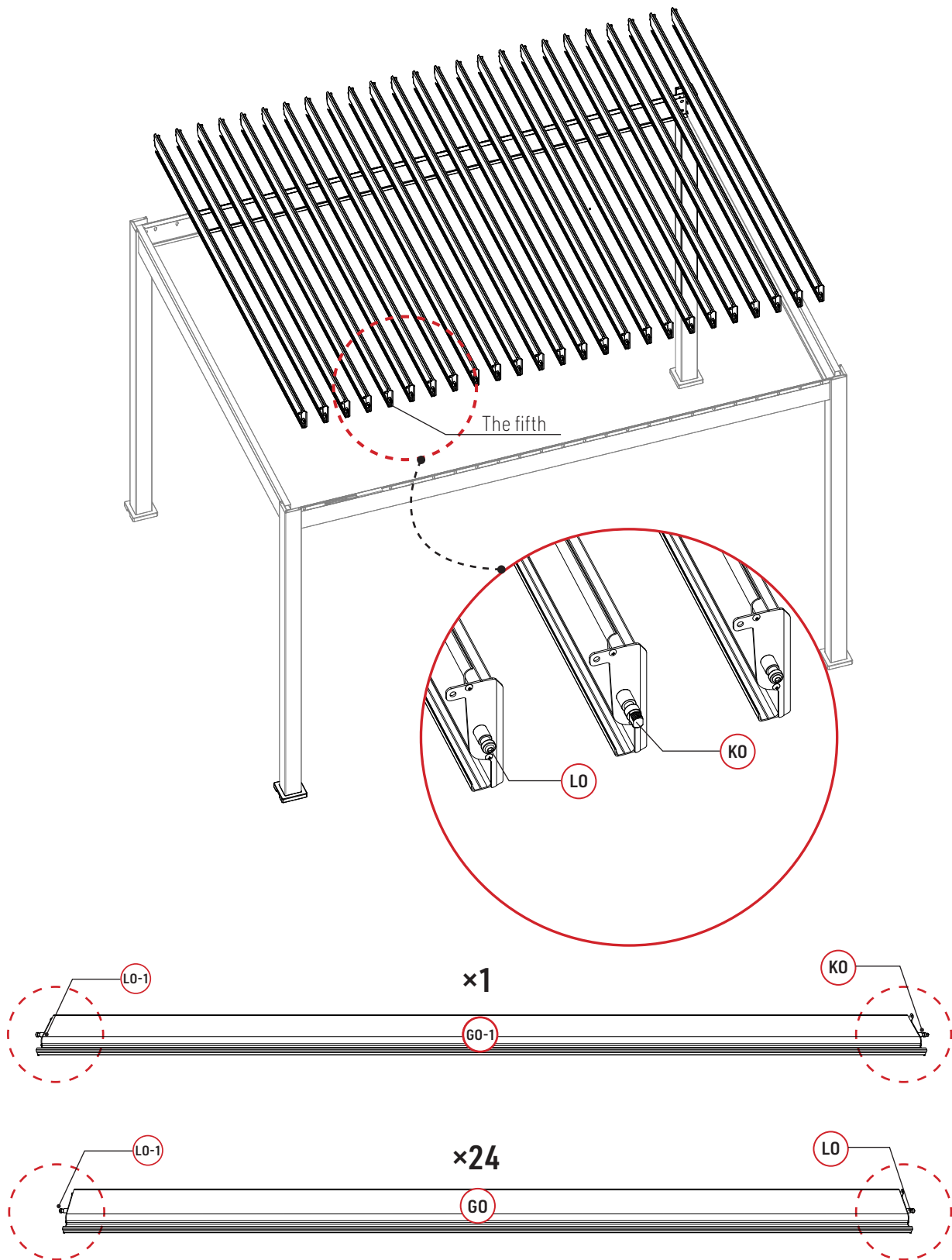

STEP 3



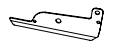

The pergola is made up of 25 slats: 24 **GO** slats and 1 **GO-1** slat, different from the others, which will be the main slat. The fifth blade from the left will be your main **GO-1** blade, connected directly to the engine.

STEP 3

LO		24	XO		49
LO-1		25	UO		49
MO		49			

TOOLS

ZO-1		1
ZO-2		1



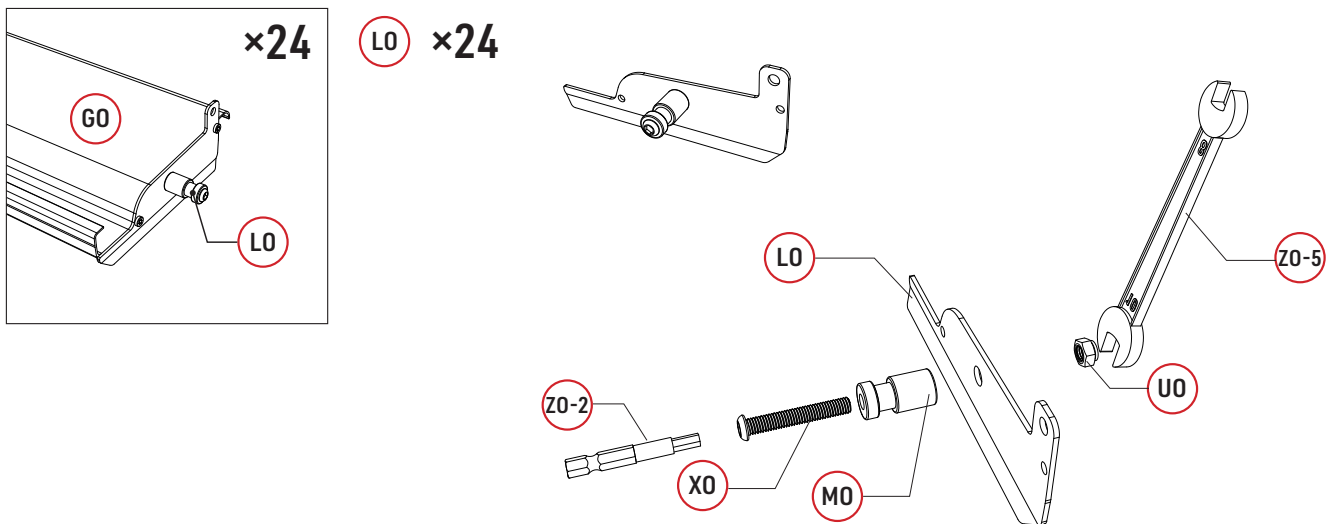

Build the pin composed of the parts **XO**, **MO** and **UO** onto the end caps **LO** and **LO-1**. Make sure the pins are installed in the right direction as shown. Please, note that the direction is different for the parts **LO** and **LO-1**.

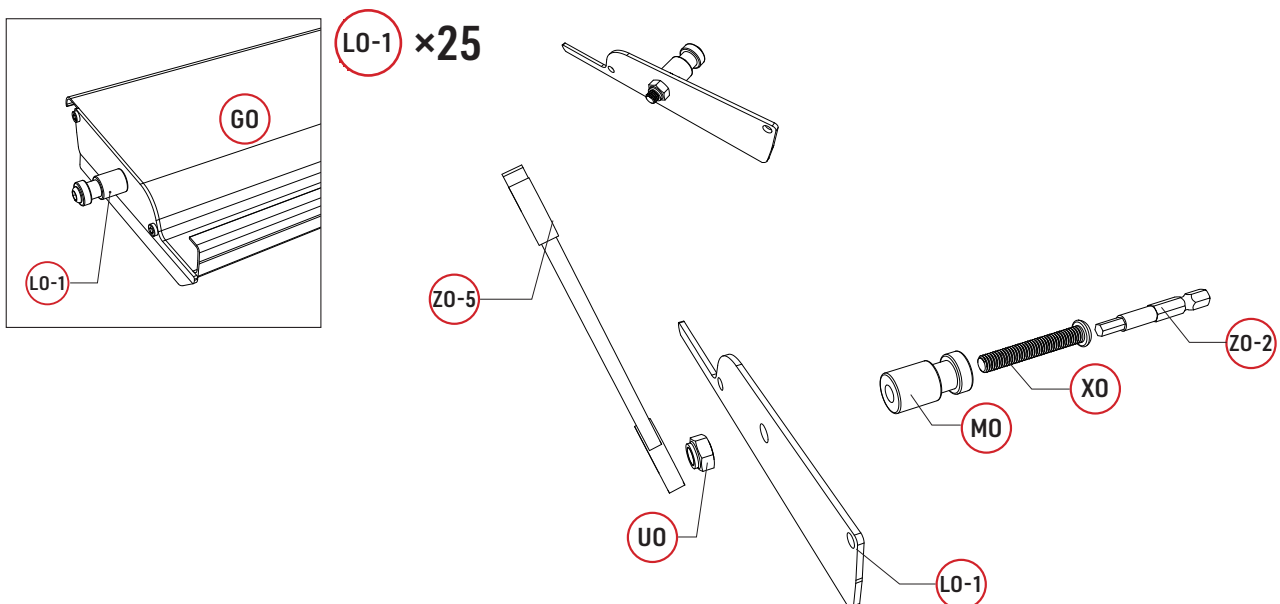



Use an electric screwdriver with the hex bit **ZO-2** to insert the bolt **XO** onto the nut **UO** for more convenience. To avoid any injury and to make it easier, we recommend you to secure the nut with the wrench **ZO-5** during this operation.



STEP 3

GO		25
KO		1
LO		24
LO-1		25
WO		100

ZO-1		1
ZO-2		1
ZO-6		1

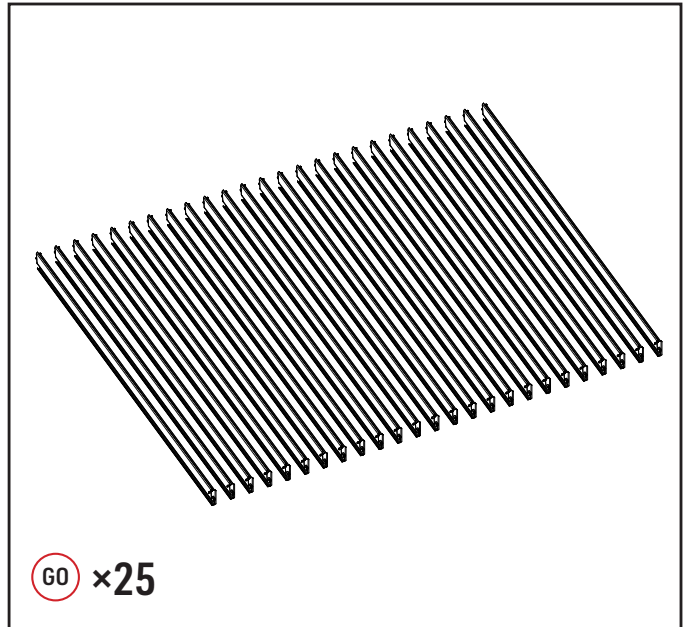

To assemble your **GO-1** blade, attach the **KO** blade cover on the right and the **LO-1** on the left. Use the **WO** screws and the **ZO-6** spanner as shown in the diagram.

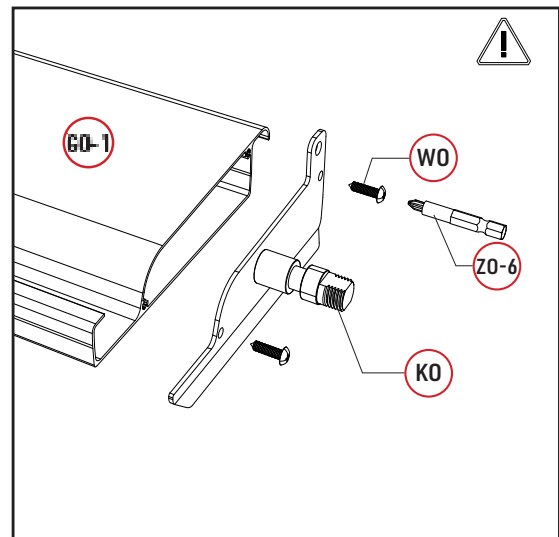
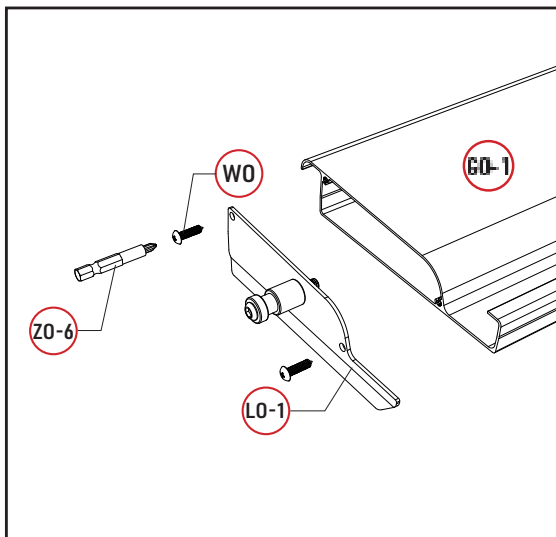
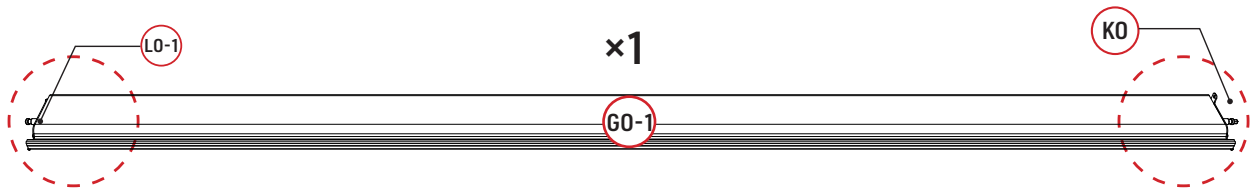

Make up and fix the pin corresponding to the **XO**, **MO** and **UO** assembly in the covers **LO** and **LO-1** blade covers. Make sure that the pin is fitted in the correct direction for the **LO** part and for the **LO-1**, as shown in the diagram.

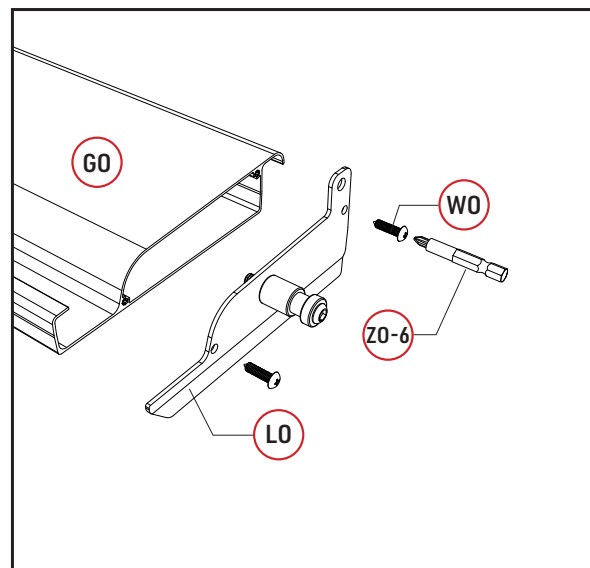
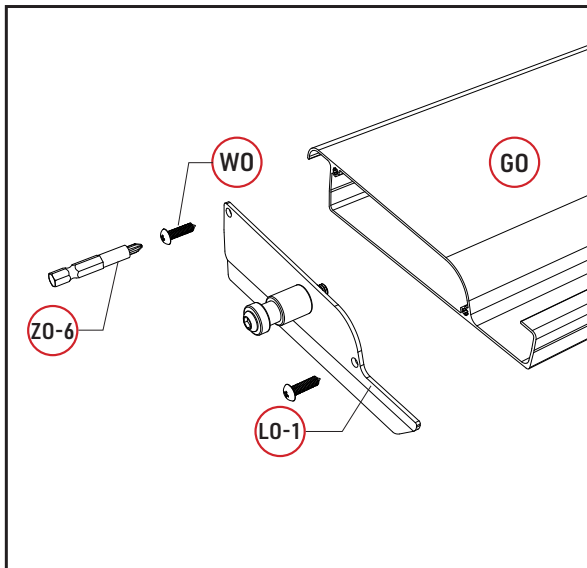
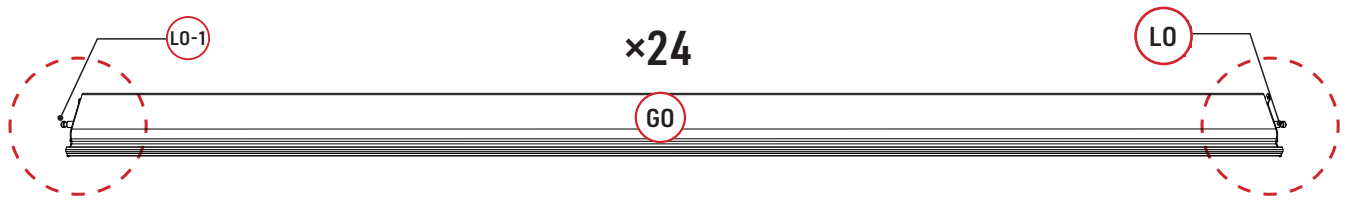

STEP 4

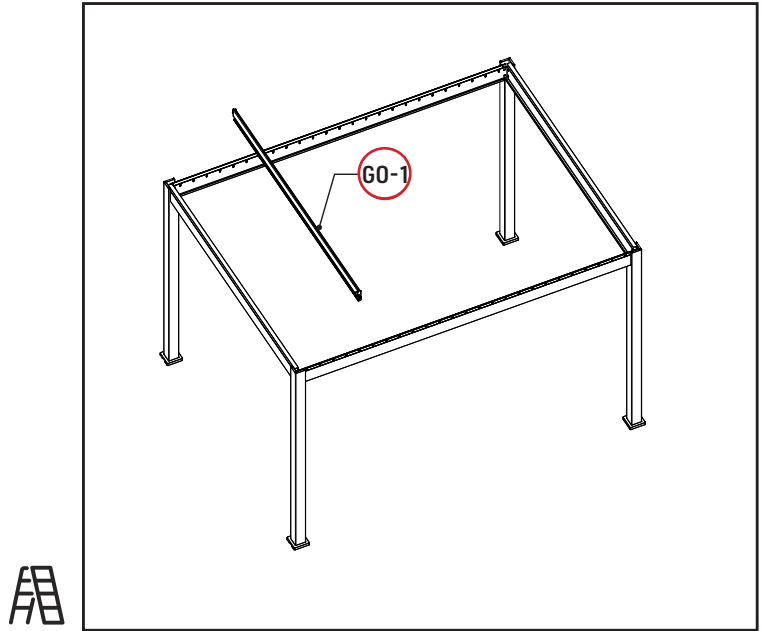

Insert the main blade in the fifth position from the left on the **BO** beam. The **KO** blade cover must be fitted on the **BO** beam side.

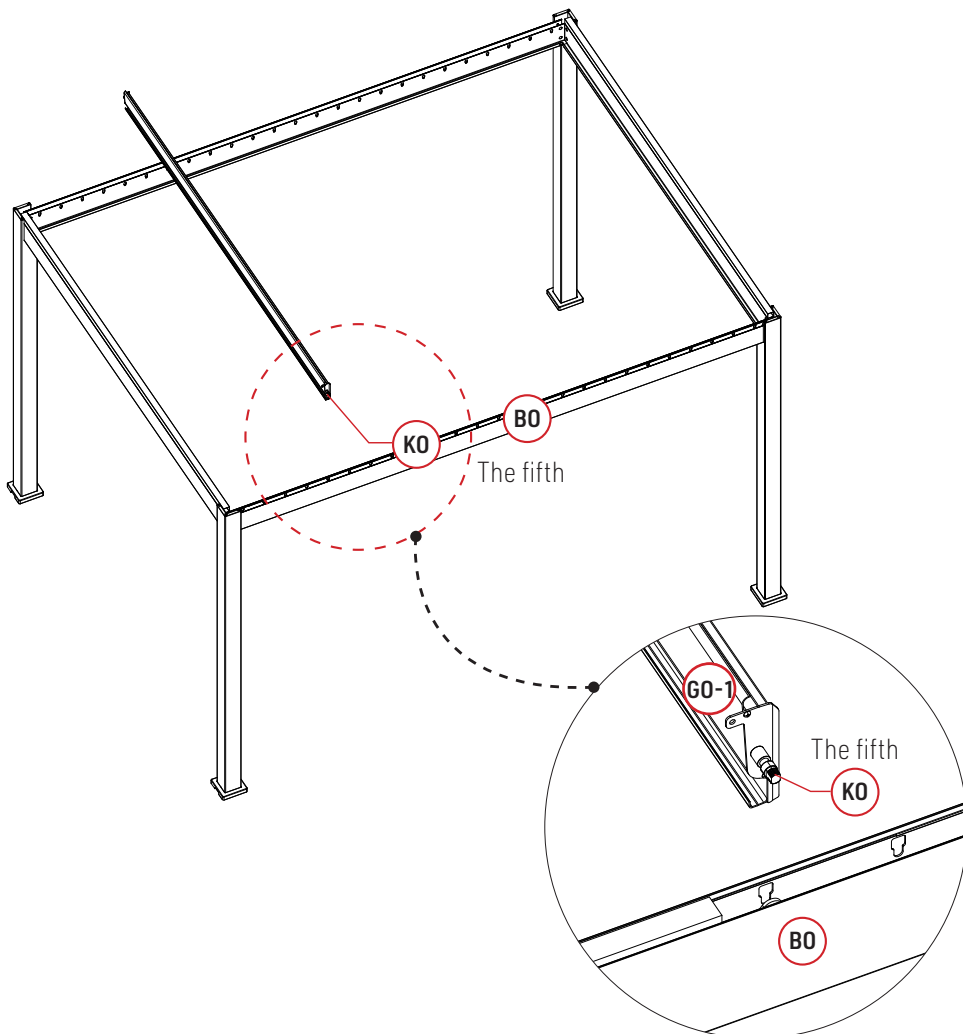

1

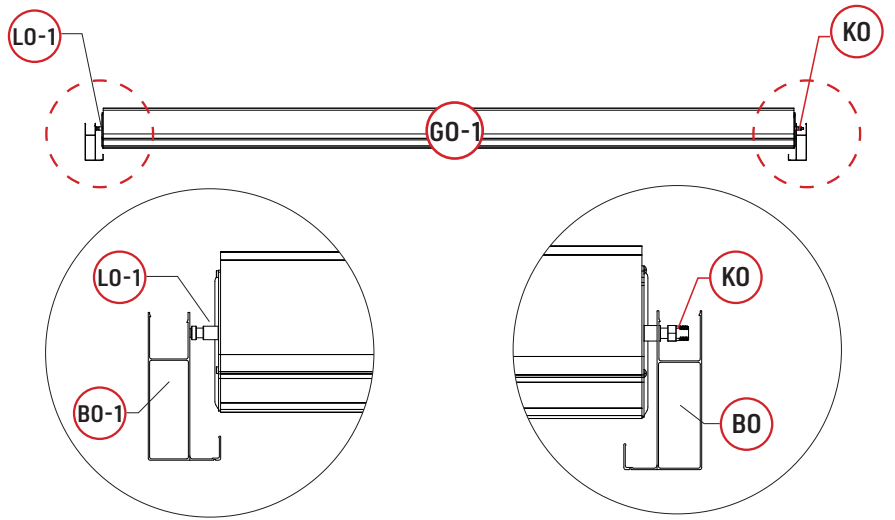
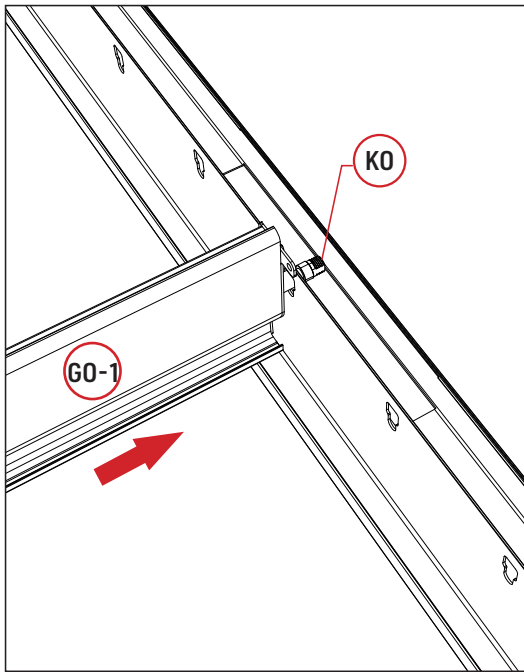

2

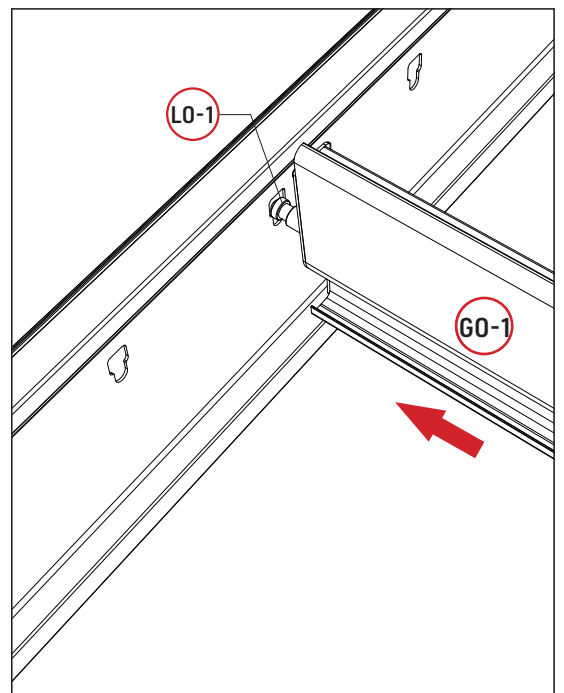
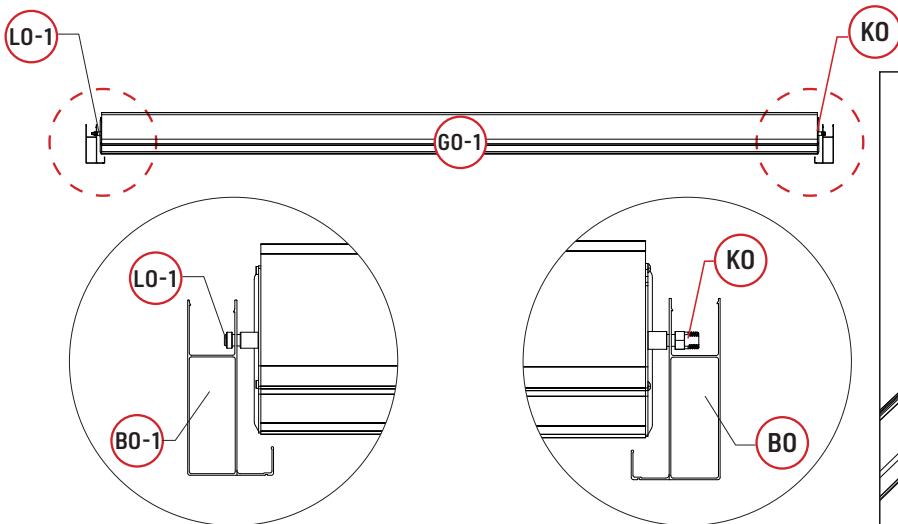

STEP 4

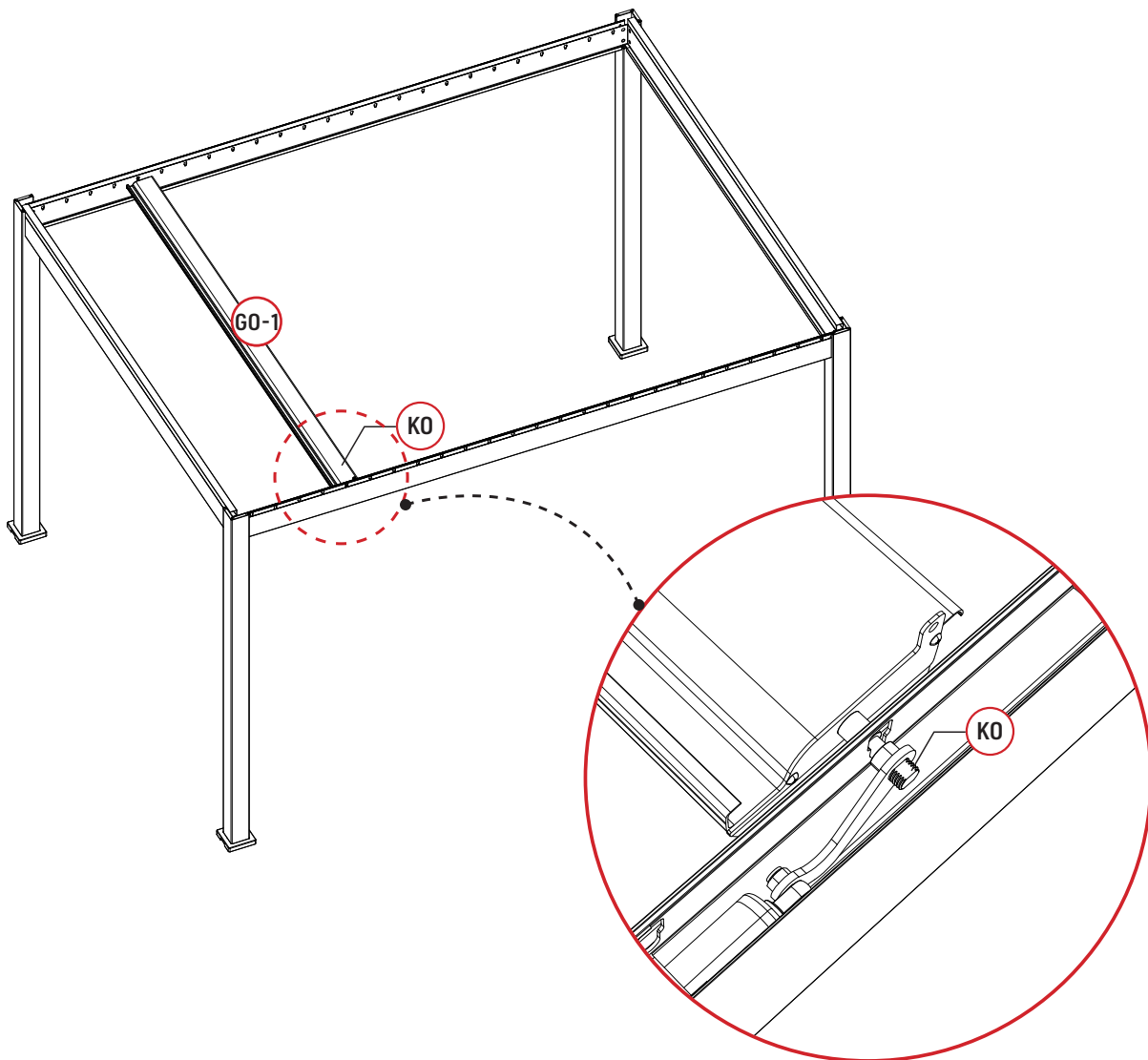
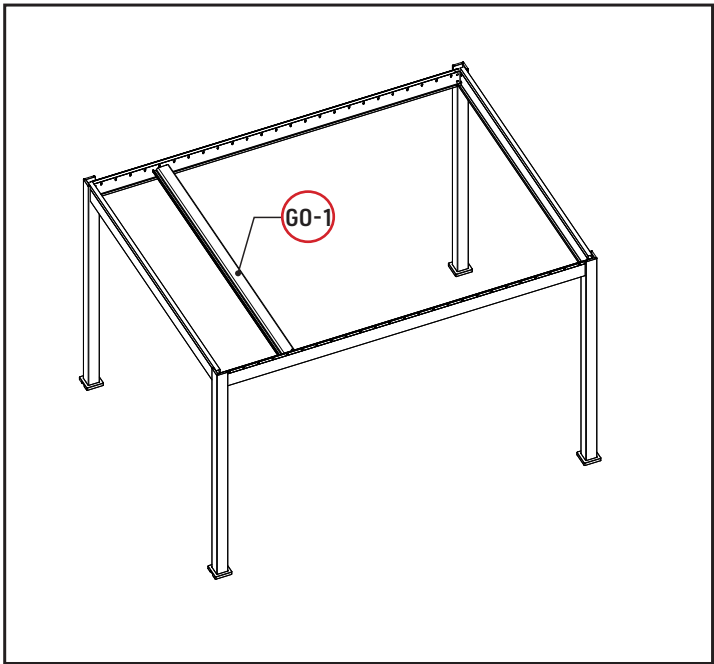

Loosen the screws on the **BO** beam using the **ZO-3** allen key to insert the motor arm into the **KO** blade cover lug, then tighten the **UO-3** nut using a spanner. Tighten the screws removed earlier using the **ZO-3** Allen key.

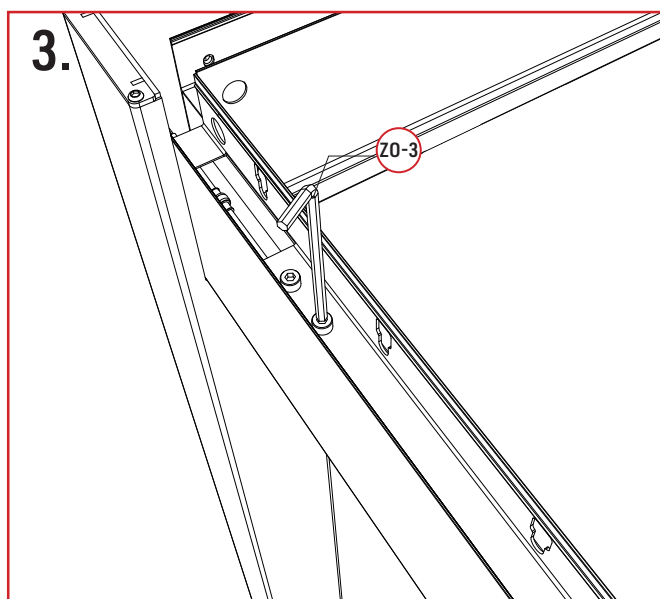
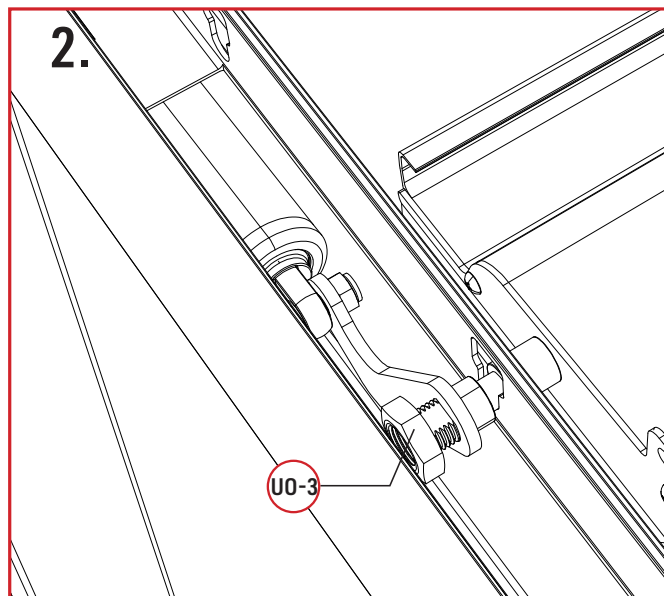
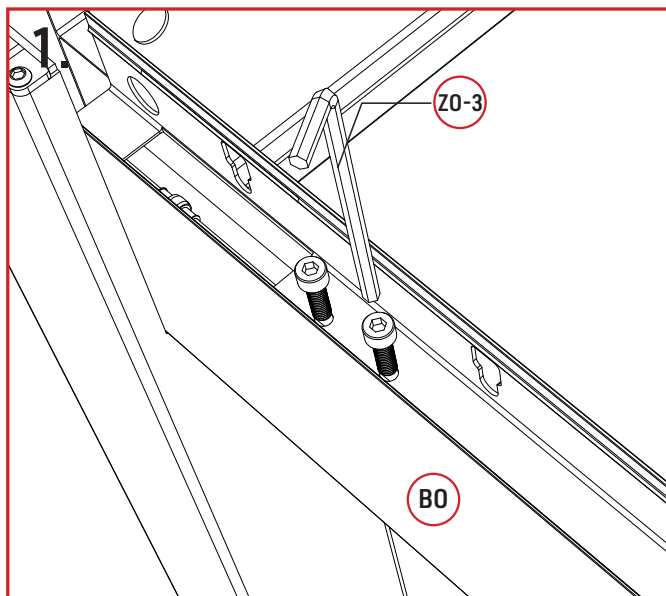

STEP 4

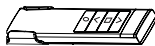
E-R		1
-----	---	---

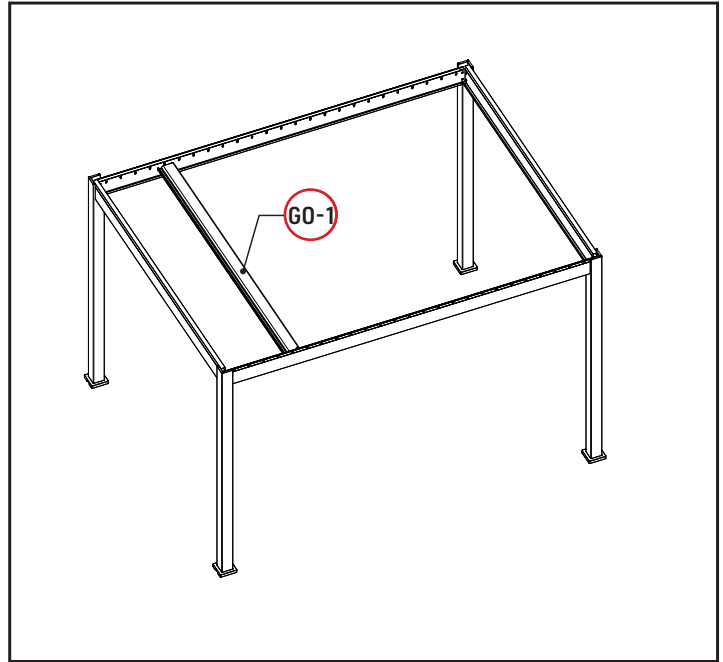

Step 1: Take the remote control with you.

Step 2 & 3: Press and hold the first “up” button on the remote control, while connecting the transformer to the power supply.

Connecting the transformer to the power supply.

Step 4: After about 5 seconds you will hear a beep indicating that the remote control has been paired with the motor.

Remote control and the motor, so you can now release the “up” button.

Step1.

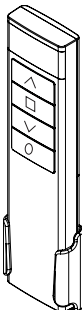

Step2.

Press and hold
for 5 seconds

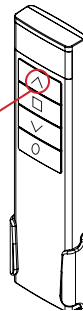

Step3.



POWER



Step4.

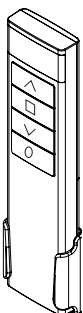

DING

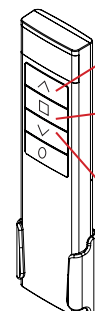
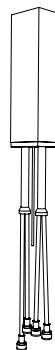

Up

Pause

Down

Use the remote control to position the main blade vertically at 90°.

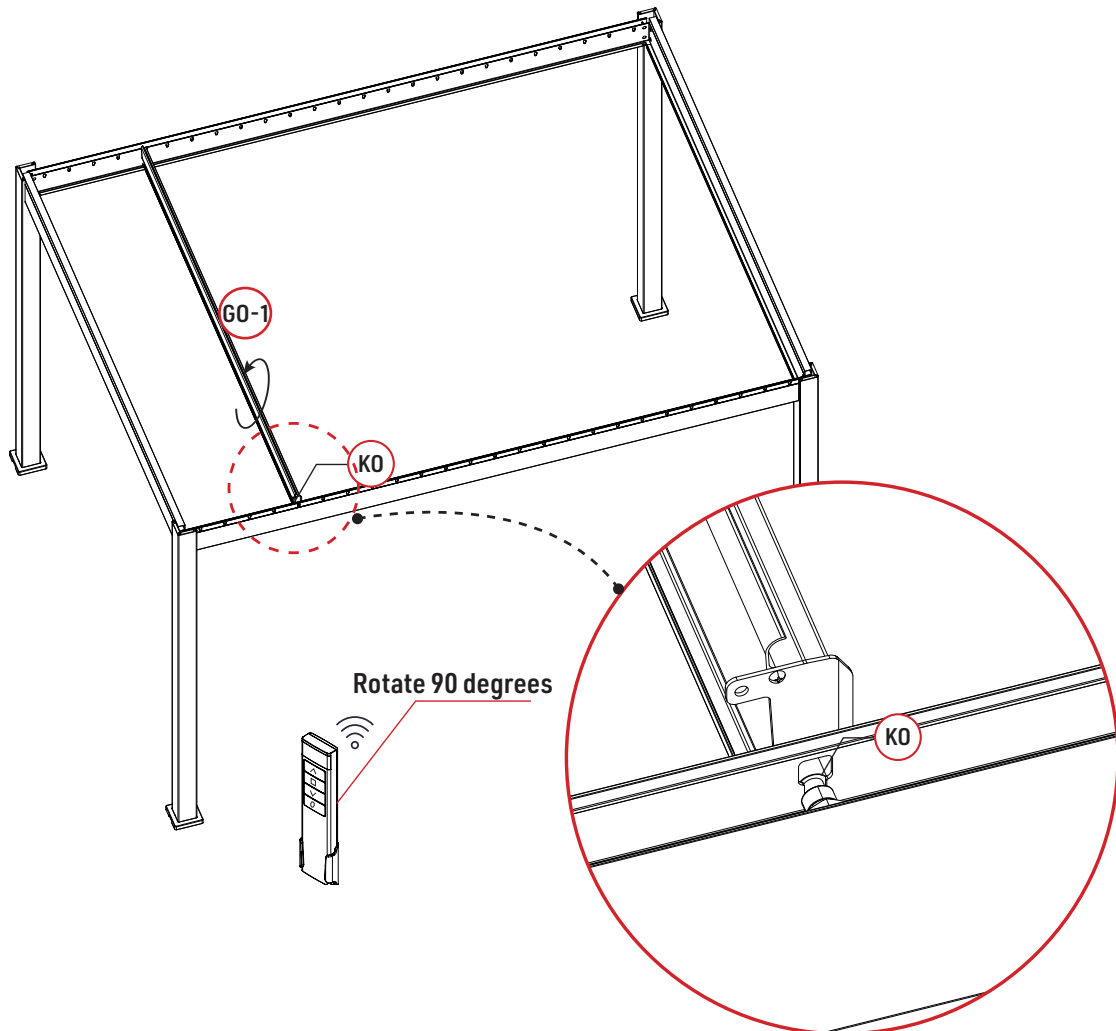

STEP 4

S0		50
----	---	----

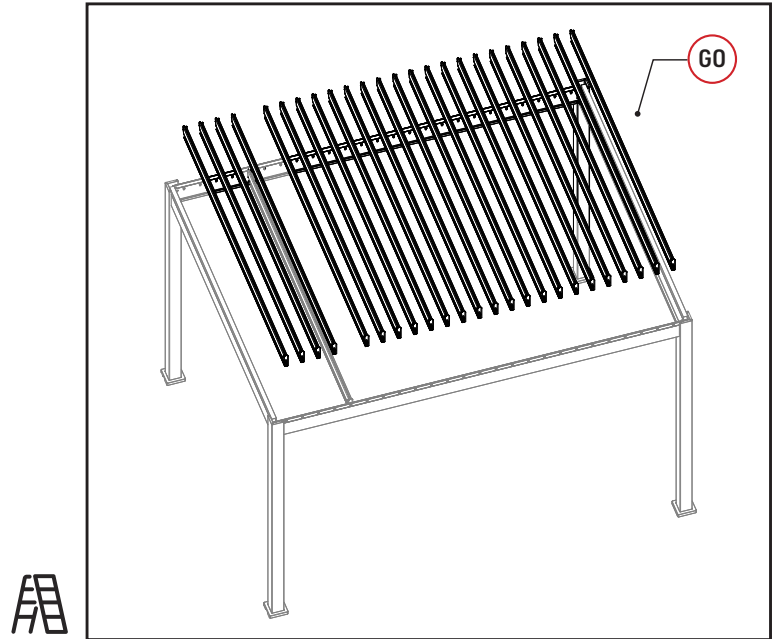

Install the 24 blades on the **BO** and **BO-1** beams.

Insert the half-moon plastic cap **S0** as shown in the drawing. The half-moon opening should stay at the bottom of the cap.

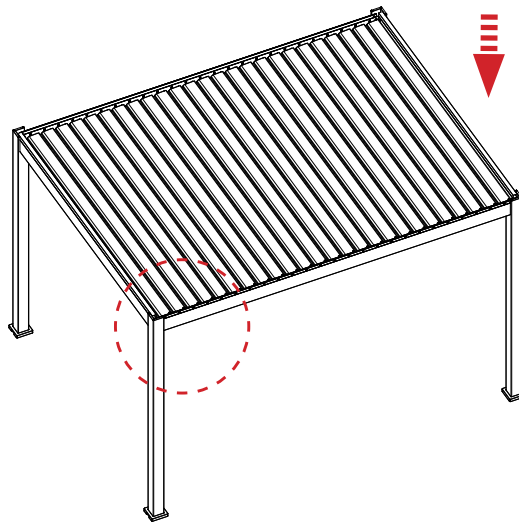

1



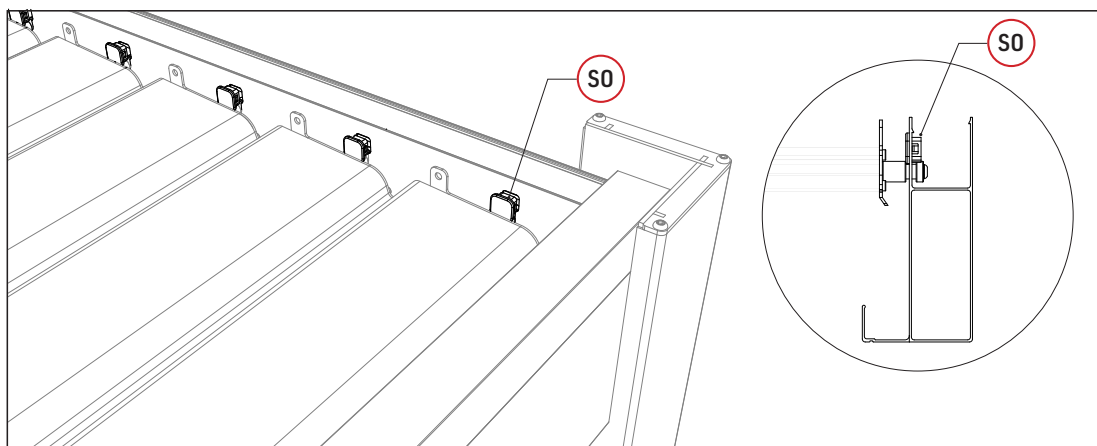

2



STEP 4

FO		1
VO		25
UO	 lock nut	25

ZO-1	 4mm	1
ZO-2	 4mm	1
ZO-5	 10mm	1

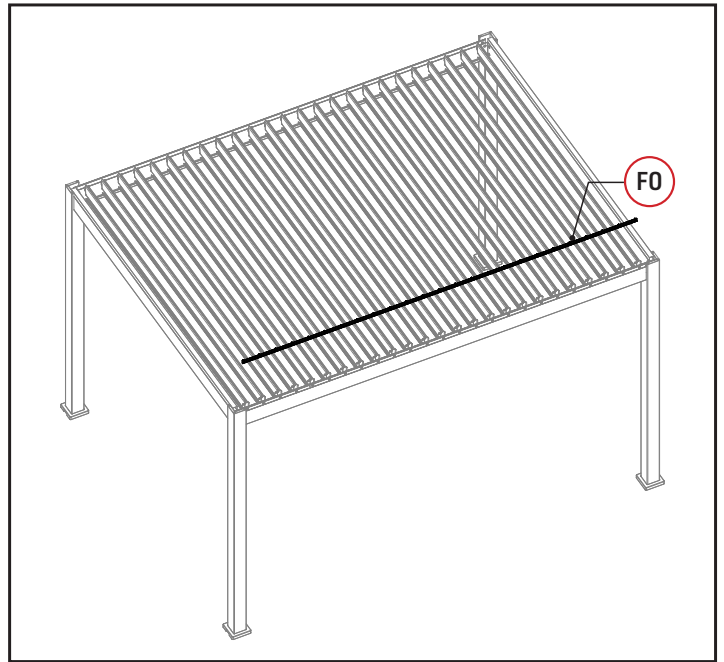

Fasten the **FO** connection bar to all the blades in the following order:



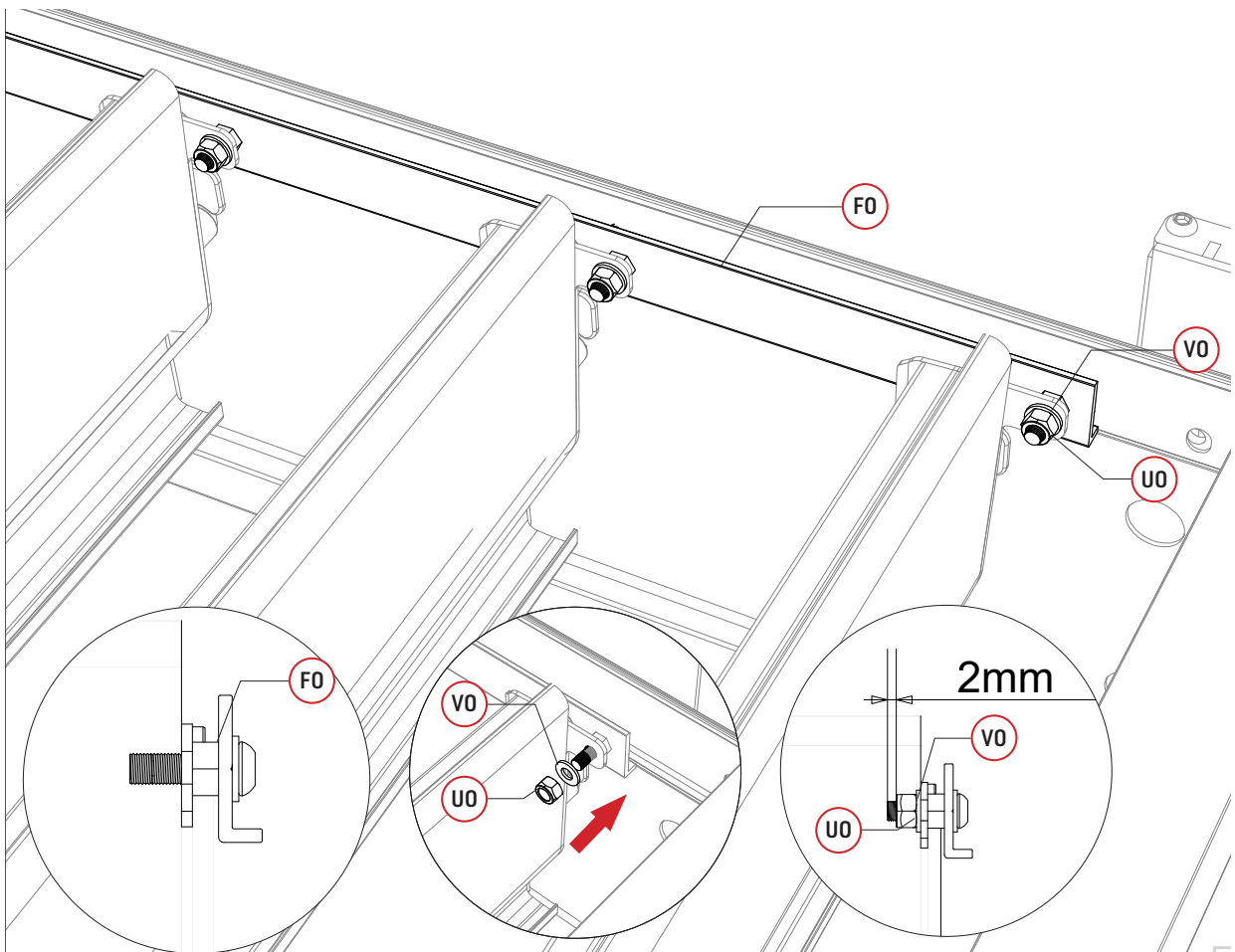

- Insert two **VO** pieces into the **XO-2** bolt,
- Pass the assembly through the louver end cap, then add the plastic nut **UO-1**.
- Pass the assembly through the **FO** connection bar,
- Add a **VO** part and a **UO** nut.

To complete the operation, use a screwdriver, the **ZO-6** bit and the **ZO-5** spanner to hold the nut in place.

Repeat the operation on all the blades, as shown in the diagram.



STEP 4

DO			2
RO			16
TO		10*80	16

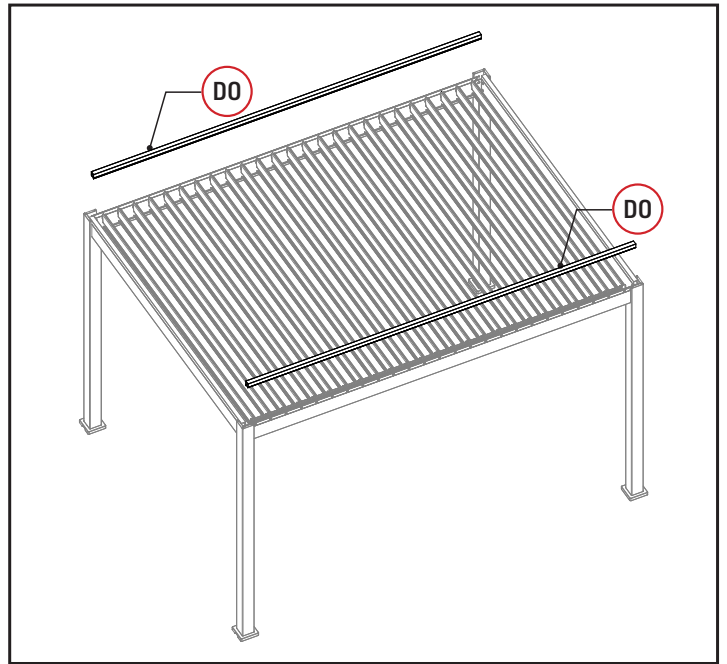

Insert the button cover **RO** on the corner of the frame as shown in the drawing.

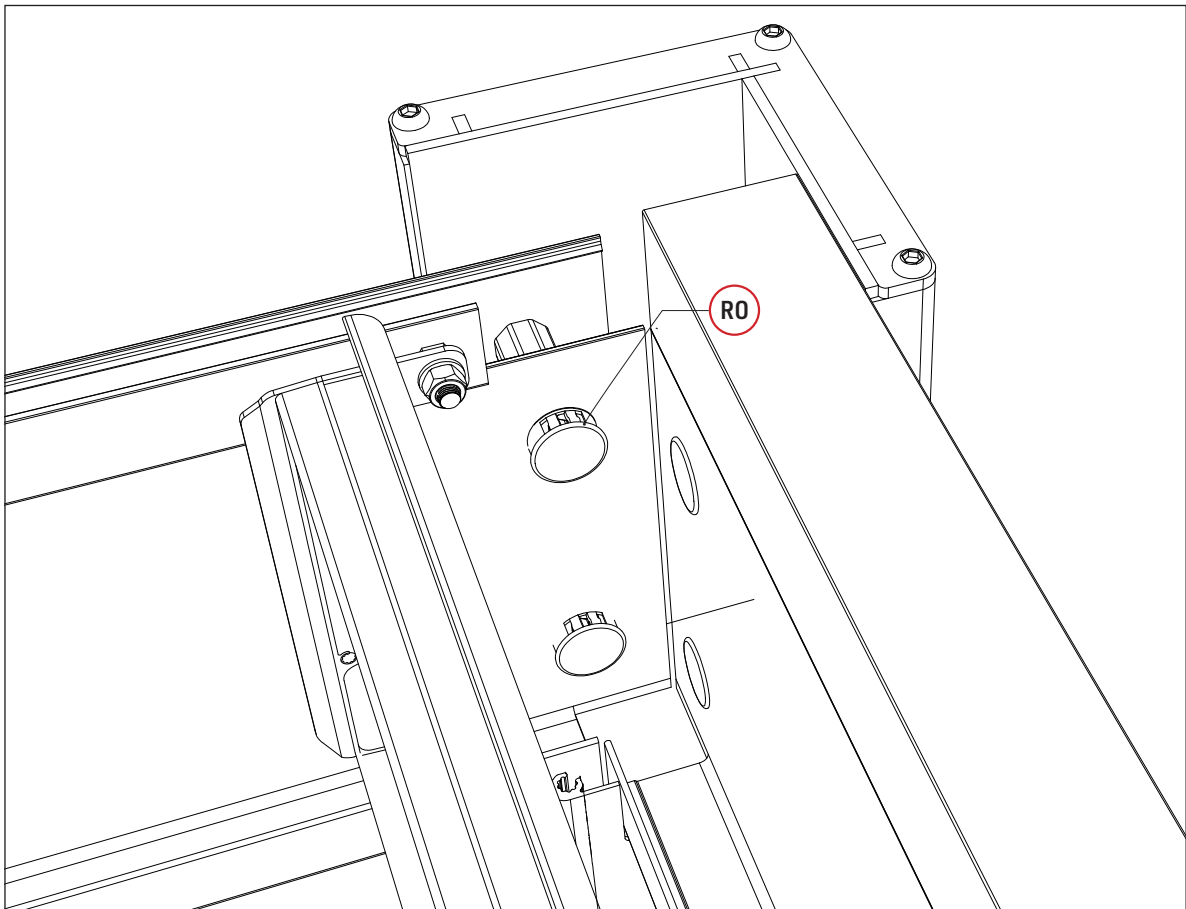

Carry out a motor test with the remote control to ensure that the slats tilt correctly, then install and fit the **DO** extensions onto the beams as shown in the diagram.

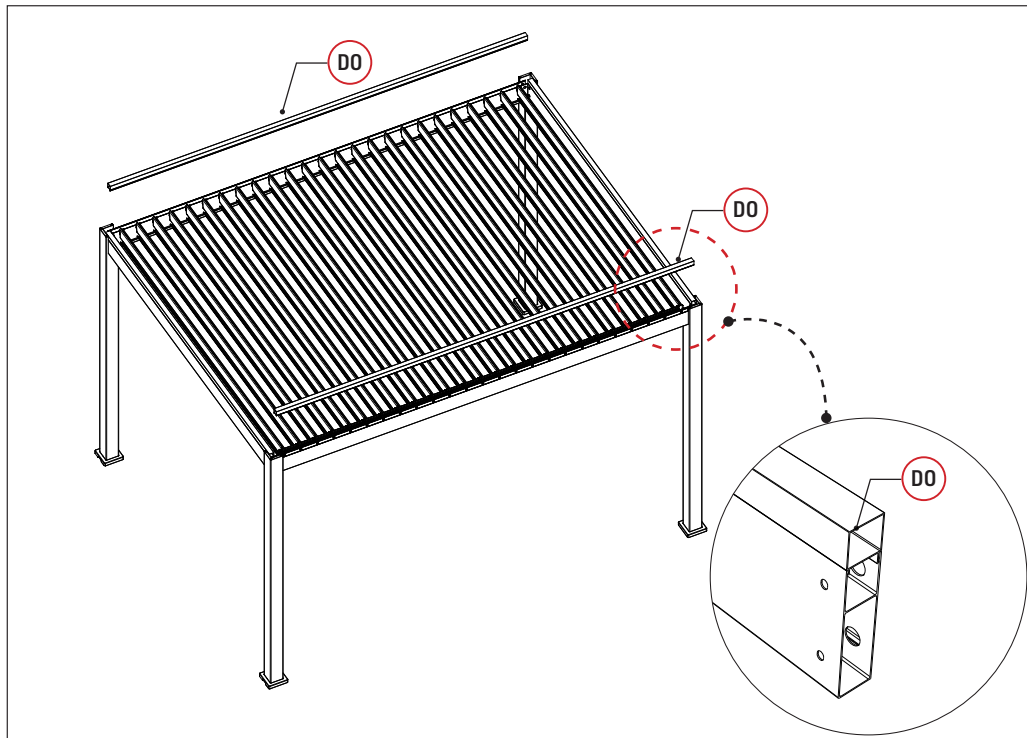

End by anchoring the pergola on a hard and flat concrete floor with the concrete expansion anchor bolts **TO**, using an electric drill and the 12mm Drill bit (not supplied).

